



REVOLUTION HD

Mobile Refuse Cart Lifter

Maximizing Route Safety & Efficiency.

Bayne Thinline Premium Lift Systems. Lifting Ergonomics To New Heights.

The Revolution® HD is an advanced modern cart lifter from Bayne® Thinline® Premium Lift Systems. This patented design incorporates a sweeping action that automatically adjusts for uneven terrain, preventing operators from having to manually hoist carts onto the lift plate. The Revolution HD was specifically designed to offer the most ground clearance possible for rear-load applications. This feature makes it a perfect choice for rear-loaders with a commercial container lift and provides the versatility to pick up both residential and commercial waste on the same route.

- Powered by the patented Bayne Thinline rack-and-pinion rotary actuator for smooth operation
- Compatible with standard domestic style two-bar roll-out carts
- Sweeping motion allows for an increased cart pick-up envelope
- Over 22" of ground clearance
- Compact design works in conjunction with most commercial container lift bars
- With a 51-degree dump angle, the carts are dumped higher and deeper inside the hopper opening to prevent spillage and increase route stops before cycling the packer panel
- Powder-coated finish for durability
- 3-year limited warranty
- All pivot points are equipped with replaceable, greasable bronze bearings to reduce wear and provide a smoother, quieter operation
- A 228% increase in overall bearing surfaces allows for up to a 50% longer life span over previous versions



Premium Lift Systems

Precision, Quality, and Patented Engineering

For more information: Toll Free: 800-528-5308 | www.baynethinline.com

Bayne Thinline Premium Lift Systems | 4301 Gault Ave. North | Fort Payne, AL 35967

REVOLUTION HD Specifications & Dimensions

PERFORMANCE SPECIFICATIONS

Cart Compatibility	ANSI Z 245.60-2008 Type B carts (domestic style 2-bar)
Lift Capacity	400 lbs. @ 1800 psi
Hydraulic Pressure	Maximum pressure - 3000 psi
Hydraulic Flow	2.0 - 2.5 gpm
Cycle Time	8 - 10 seconds
Bearings	Replaceable bronze bearing
Actuator	Patented Bayne® Thinline® rack-and-pinion rotary actuator
Finish	Safety yellow powder-coating
Options	Tap-in Kit
	Mounting-plate kit for bolt-on application
	Commercial container bumper kit



How It Works:

The Bayne Thinline patented design incorporates a sweeping action that automatically adjusts for uneven terrain, preventing operators from having to manually hoist carts onto the lift plate. The Revolution® HD was specifically designed to offer the most ground clearance possible for rear-load garbage truck applications. The Revolution HD also works with Rear-Loaders that utilize a kick bar.

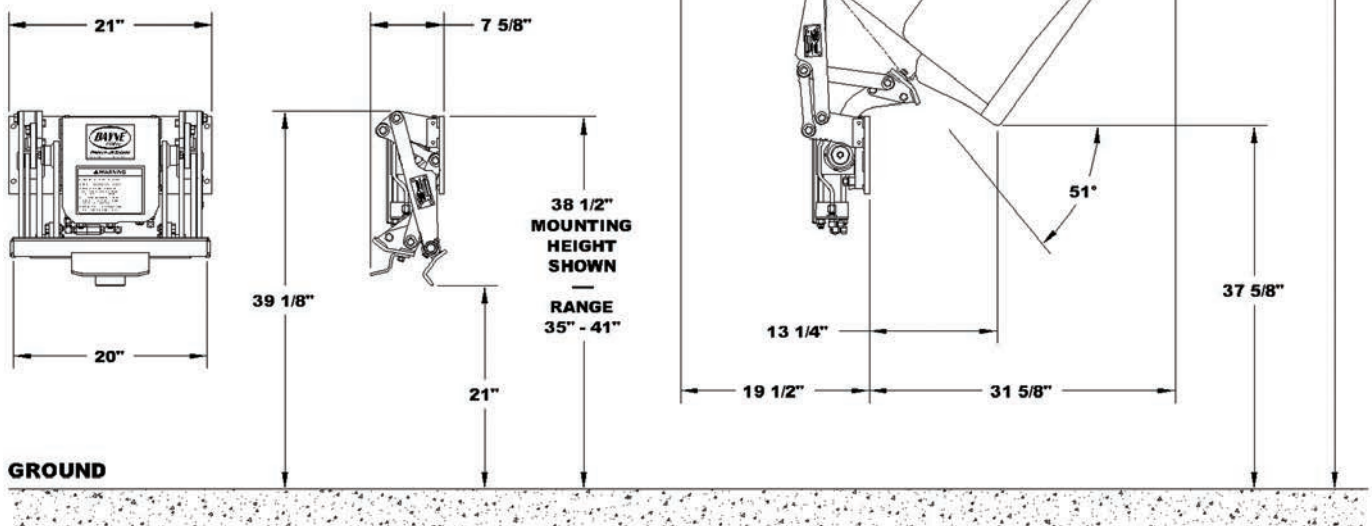

Pictures and mechanical diagrams in this literature are illustrative only and may not be to scale. Specifications are subject to change without notice in order to accommodate improvements to the equipment. Data published herein is for information purposes only and shall not be construed to warrant suitability of the unit for any particular purpose, as performance may vary with the conditions encountered. The only warranty is our standard written Warranty Statement for this product at the time of shipment.



Premium Lift Systems

Toll Free: 800-528-5308 | www.baynethinline.com

Bayne Thinline Premium Lift Systems | 4301 Gault Ave. North | Fort Payne, AL 35967

© Copyright 2024 Bayne Thinline All rights reserved

