



MBTL-180

Mobile Refuse Cart Lifter

Maximizing Route Safety & Efficiency

Bayne Thinline Premium Lift Systems. Lifting Ergonomics To New Heights.

The MBTL-180 takes one of the best-selling, most dependable lifters from Bayne® Thinline® Premium Lift Systems and makes it even better. This lifter offers all the best characteristics of the original MBTL, like industry leading ground clearance, solid hook-drive mechanism, and no packer blade interference. However, with its improved dump height and depth, the MBTL 180 prevents spillage and increases route stops before needing to cycle the packer blade.

MBTL-180 Features:

- Powered by the patented Bayne Thinline rack-and-pinion rotary actuator for smooth operation
- Compatible with standard domestic style 2-bar roll-out carts
- Solid hook-drive mechanism automatically secures the cart to the lift plate during the dump cycle
- Over 19" of ground clearance reduces the risk of damaging the lifter on uneven terrain
- Sweeping motion for increased cart pick-up envelope
- Will not interfere with packer panel when properly mounted
- Powder-coated finish for durability
- 2-Year Limited Warranty



Premium Lift Systems

Precision, Quality, and Patented Engineering

For more information: Toll Free: 800-528-5308 | www.baynethinline.com
Bayne Thinline Premium Lift Systems | 4301 Gault Ave. North | Fort Payne, AL 35967

MBTL-180

Specifications & Dimensions

PERFORMANCE SPECIFICATIONS

Cart Compatibility	ANSI Z 245.60-2006 Type B Carts (domestic style 2-bar)
Lift Capacity	400 lbs. @ 1600 psi
Hydraulic Pressure	Working Pressure – 1600 psi Maximum Pressure – 2500 psi
Hydraulic Flow	2.0 – 2.5 gpm
Cycle Time	6 – 8 seconds
Bearings	Self-Lubricating Composite Material
Actuator	Patented Bayne® Thinline® rack-and-pinion rotary actuator
Finish	Safety yellow powder-coating
Options	Tap-in Kit
	Mounting-plate kit for bolt-on application



How It Works:

The patented Bayne Thinline design incorporates a sweeping action that automatically adjusts for uneven terrain, preventing operators from having to manually hoist carts onto the lift plate. The MBTL-180 was specifically designed to offer the most ground clearance possible for rear-load garbage truck applications.

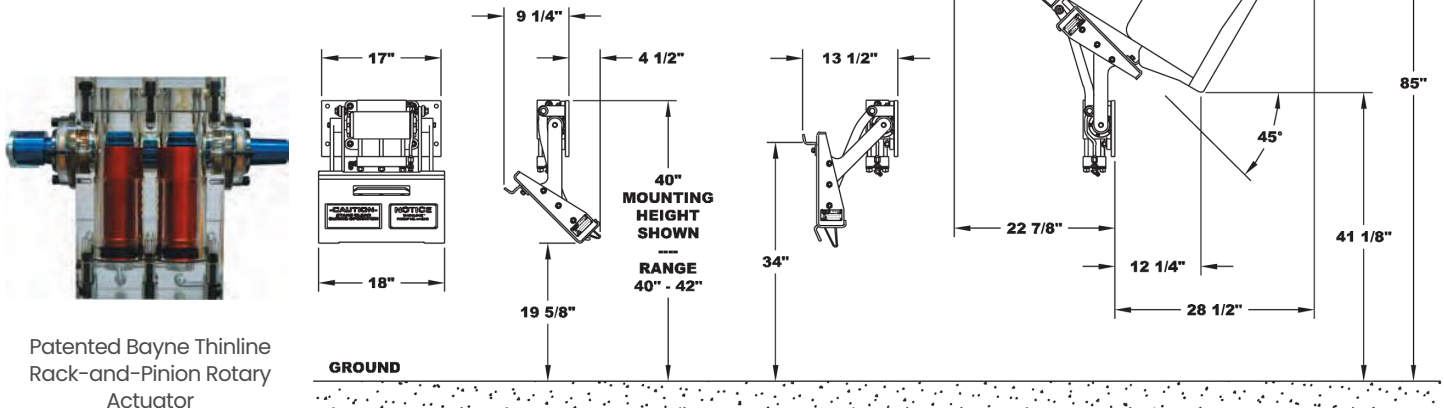

Pictures and mechanical diagrams in this literature are illustrative only and may not be to scale. Specifications are subject to change without notice in order to accommodate improvements to the equipment. Data published herein is for information purposes only and shall not be construed to warrant suitability of the unit for any particular purpose, as performance may vary with the conditions encountered. The only warranty is our standard written Warranty Statement for this product at the time of shipment.



Premium Lift Systems

Toll Free: 800-528-5308 | www.baynethinline.com

Bayne Thinline Premium Lift Systems | 4301 Gault Ave. North | Fort Payne, AL 35967

© Copyright 2024 Bayne Thinline All rights reserved

