



C/I TASKMASTER SERIES

Commercial and Industrial Refuse Cart Lifters

Dynamic. Cost-Effective. Strong.

Bayne Thinline Premium Lift Systems. Lifting Ergonomics To New Heights.

The C/I Taskmaster series from Bayne® Thinline® Premium Lift Systems offers an economical and safety conscious solution for a wide variety of waste material-handling applications. This series of Commercial and Industrial lifters combines our advanced line of cylinder lift products mounted on rigid steel frames. C/I Taskmaster cart lifters, or cart tipplers, come standard with a hydraulic power unit, electrical controls, and are ideal for use with balers and compactors.

C/I Taskmaster Series Features:

- Available in 3 different options (Taskmaster, Taskmaster Hi-Lift, and Taskmaster Super Hi-Lift)
- Compatible with all standard 2-bar domestic carts
- Cycle times as low as 8 seconds
- Up to 1,000 lbs. lift capacity
- Strong ¼" wall structural steel tubing
- Sweeping action provides a greater pick-up envelope for lifting carts on uneven terrain
- Dumps well inside hopper to prevent spillage
- Easy-to-use pendant control is standard
- Self-lubricating composite bearings eliminate the need for greasing
- Non-adjustable solid hook-drive mechanism automatically secures cart during the dump cycle
- Powder-coated finish for durability
- 1-year limited warranty



Premium Lift Systems

Precision, Quality, and Patented Engineering

For more information: Toll Free: 800-528-5308 | www.baynethinline.com

Bayne Thinline Premium Lift Systems | 4301 Gault Ave. North | Fort Payne, AL 35967

C/I Taskmaster Features:

- 42 1/2" dump-over height
- 87 3/8" overhead height
- 45-degree dump angle
- 550 lbs. lift capacity
- 8-second cycle time

PERFORMANCE SPECIFICATIONS

Cart Compatibility	ANSI Z 245.60-2008 Type B Carts (domestic style 2-bar)
Lift Capacity	550 lbs. @ 1800 psi
Hydraulic Pressure	Working Pressure – 1800 psi Maximum Pressure – 2500 psi
Hydraulic Flow	1.8 gpm
Cycle Time	8 seconds
Bearings	Self-Lubricating Composite Material
Cylinder	Welded Construction With Replaceable Seals 2.5" Bore x 6" Stroke
Finish	Safety Yellow Powder-Coating
Power Unit	5 HP Motor (460V three-phase)

NOTE:

1. COMPATIBLE CONTAINERS:
ANSI Z245.60-2008 TYPE B CONTAINERS (domestic 2-bar carts)
2. LIFT CAPACITY: 550 lbs @ 1800 PSI
3. CYCLE TIME: 8 SECONDS @ 1.8 GPM
4. POWER UNIT: 5 HP MOTOR (460V three-phase)
1.8 GPM GEAR PUMP
4 GALLON OIL RESERVOIR
2500 PSI MAXIMUM PRESSURE
KEYED ON/OFF SWITCH
HAND HELD PENDENT CONTROL w/ 6' CORD
5. ALL DIMENSIONS ARE APPROXIMATE.

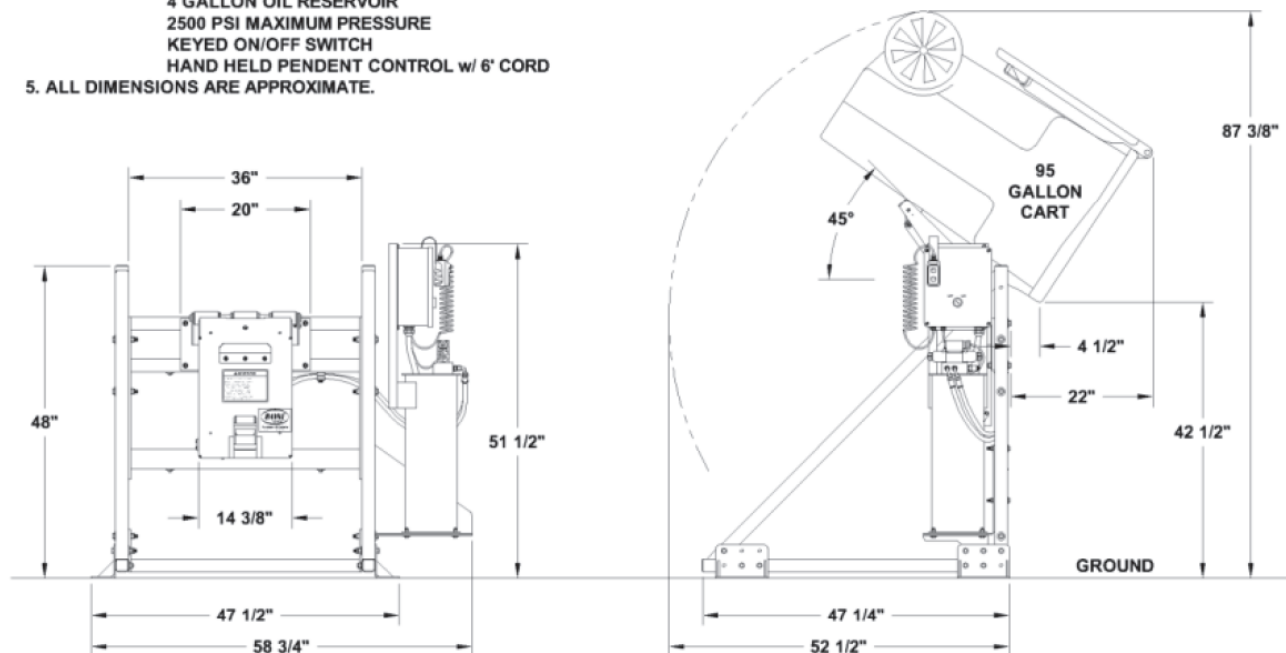

Pictures and mechanical diagrams in this literature are illustrative only and may not be to scale. Specifications are subject to change without notice in order to accommodate improvements to the equipment. Data published herein is for information purposes only and shall not be construed to warrant suitability of the unit for any particular purpose, as performance may vary with the conditions encountered. The only warranty is our standard written Warranty Statement for this product at the time of shipment.



Premium Lift Systems

Toll Free: 800-528-5308 | www.baynethinline.com

Bayne Thinline Premium Lift Systems | 4301 Gault Ave. North | Fort Payne, AL 35967

© Copyright 2023 Bayne Thinline All rights reserved



C/I Taskmaster Hi-Lift Features:

- 60 ³/₄" dump-over height
- 105 ⁷/₈" overhead height
- 45-degree dump angle
- 750 lbs. lift capacity
- 12-second cycle time

PERFORMANCE SPECIFICATIONS

Cart Compatibility	ANSI Z 245.60-2008 Type B Carts (domestic style 2-bar)
Lift Capacity	750 lbs @ 2500 psi
Hydraulic Pressure	Working Pressure – 2500 psi Maximum Pressure – 2500 psi
Hydraulic Flow	1.8 gpm
Cycle Time	12 seconds
Bearings	Self-Lubricating Composite Material
Cylinder	Welded Construction With Replaceable Seals 2.5" Bore x 6" Stroke
Finish	Safety Yellow Powder-Coating
Power Unit	5 HP Motor (460V three-phase)

NOTE:

1. COMPATIBLE CONTAINERS:
ANSI Z245.60-2008 TYPE B CONTAINERS (domestic 2-bar carts)
2. LIFT CAPACITY: 750 lbs @ 2500 PSI
3. CYCLE TIME: 12 SECONDS @ 1.8 GPM
4. POWER UNIT: 5 HP MOTOR (460V three-phase)
1.8 GPM GEAR PUMP
4 GALLON OIL RESERVOIR
2500 PSI MAXIMUM PRESSURE
KEYED ON/OFF SWITCH
HAND HELD PENDENT CONTROL w/ 6' CORD
5. ALL DIMENSIONS ARE APPROXIMATE.

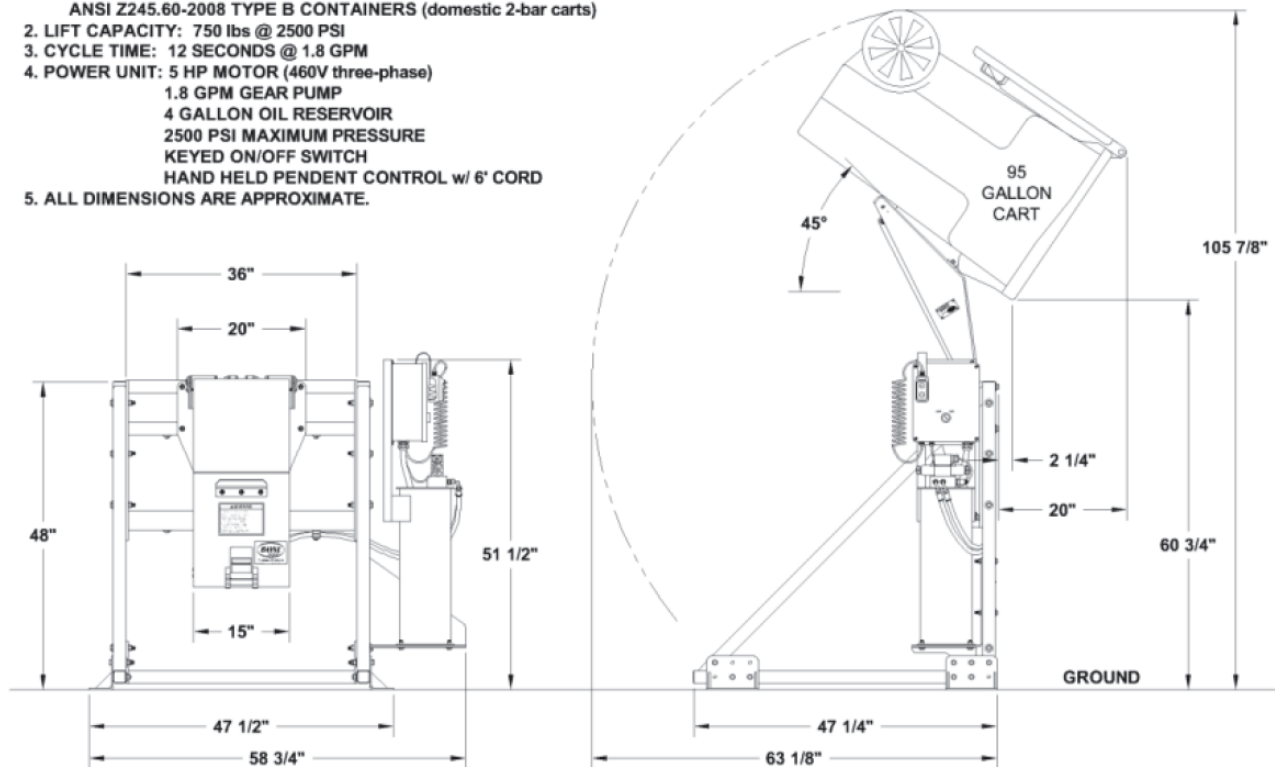

Pictures and mechanical diagrams in this literature are illustrative only and may not be to scale. Specifications are subject to change without notice in order to accommodate improvements to the equipment. Data published herein is for information purposes only and shall not be construed to warrant suitability of the unit for any particular purpose, as performance may vary with the conditions encountered. The only warranty is our standard written Warranty Statement for this product at the time of shipment.



Premium Lift Systems

Toll Free: 800-528-5308 | www.baynethinline.com

Bayne Thinline Premium Lift Systems | 4301 Gault Ave. North | Fort Payne, AL 35967

© Copyright 2023 Bayne Thinline All rights reserved



C/I TASKMASTER SUPER HI-LIFT Specifications & Dimensions

C/I Taskmaster Super Hi-Lift Features:

- Compatible with standard domestic style 2-bar carts, as well as 1/2 yd. and 1 yd. material-handling carts
- 57" dump-over height
- 137 7/8" overhead height
- 40-degree dump angle
- 1,000 lbs. lift capacity
- 12-second cycle time

PERFORMANCE SPECIFICATIONS

Cart Compatibility	ANSI Z 245.60-2008 Type B Carts (domestic style 2-bar) Plus 1/2 yd. and 1 yd. Material-Handling Carts
Lift Capacity	1,000 lbs. @ 2500 psi
Hydraulic Pressure	Working Pressure – 2500 psi Maximum Pressure – 2500 psi
Hydraulic Flow	1.8 gpm
Cycle Time	12 seconds
Bearings	Self-Lubricating Composite Material
Cylinder	Welded Construction With Replaceable Seals 2.5" Bore x 6" Stroke
Finish	Safety Yellow Powder-Coating
Power Unit	5 HP Motor (460V three-phase)

NOTE:

- COMPATIBLE CONTAINERS:**
ANSI Z245.60-2008 TYPE B CONTAINERS (domestic 2-bar carts)
AMERI-KART 1 CU. YD. MATERIAL HANDLING CART
- LIFT CAPACITY:** 1000 lbs @ 2500 PSI
- CYCLE TIME:** 12 SECONDS @ 1.8 GPM
- POWER UNIT:** 5 HP MOTOR (460V three-phase)
1.8 GPM GEAR PUMP
4 GALLON OIL RESERVOIR
2500 PSI MAXIMUM PRESSURE
KEYED ON/OFF SWITCH
HAND HELD PENDENT CONTROL w/ 6' CORD
- ALL DIMENSIONS ARE APPROXIMATE.**

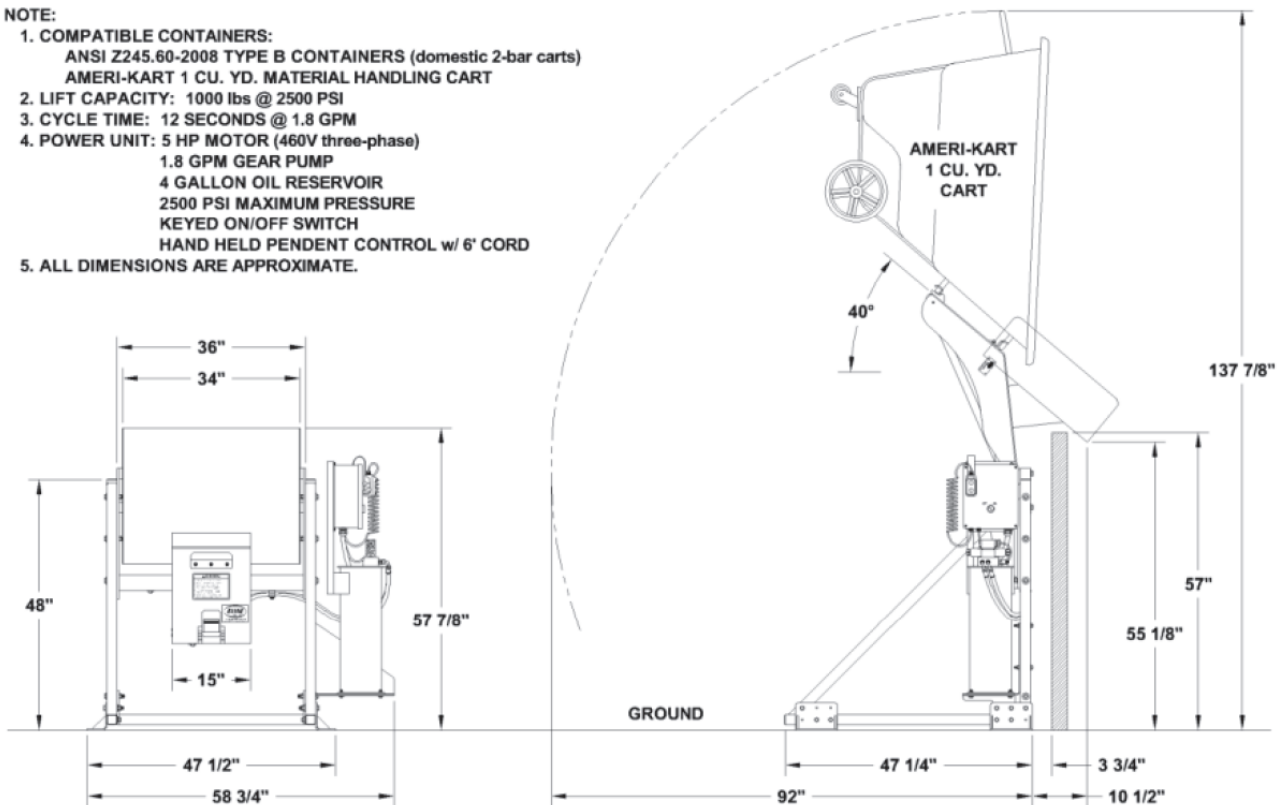

Pictures and mechanical diagrams in this literature are illustrative only and may not be to scale. Specifications are subject to change without notice in order to accommodate improvements to the equipment. Data published herein is for information purposes only and shall not be construed to warrant suitability of the unit for any particular purpose, as performance may vary with the conditions encountered. The only warranty is our standard written Warranty Statement for this product at the time of shipment.



Premium Lift Systems

Toll Free: 800-528-5308 | www.baynethinline.com

Bayne Thinline Premium Lift Systems | 4301 Gault Ave. North | Fort Payne, AL 35967

© Copyright 2024 Bayne Thinline All rights reserved

