



FEL FORK-TUBE LIFTER SERIES

Mobile Refuse Cart Lifter

Maximizing Route Safety & Efficiency.

Bayne Thinline Premium Lift Systems. Lifting Ergonomics To New Heights.

The Fork-Tube Lifter Series from Bayne® Thinline® Premium Lift Systems enables residential-waste pick-ups on a rural commercial-front-loader route. With Fork-Tube Series lifters, haulers can operate a single front-load truck on lengthy routes, resulting in increased productivity, and a reduction in total fleet costs. Lifters can be manually operated without requiring the installation of controls or routing of hydraulic lines, or can be pneumatically operated for added efficiency.

FEL Fork Tube Lifter Series Features:

- Handle commercial and residential pick-ups with a single truck
- Lower latches can be manually operated or pneumatically controlled
- No hydraulic tap-in required
- Does not interfere with commercial pickups
- Compatible with ANSI Type B domestic style two-bar carts
- Powder-coated finish for durability
- One-Year Limited Warranty



Premium Lift Systems

Precision, Quality, and Patented Engineering

For more information: Toll Free: 800-528-5308 | www.baynethinline.com

Bayne Thinline Premium Lift Systems | 4301 Gault Ave. North | Fort Payne, AL 35967

FORK-TUBE LIFTER SERIES Specifications & Dimensions

FEL Fork-Tube Lifter Series - Manually Operated Version

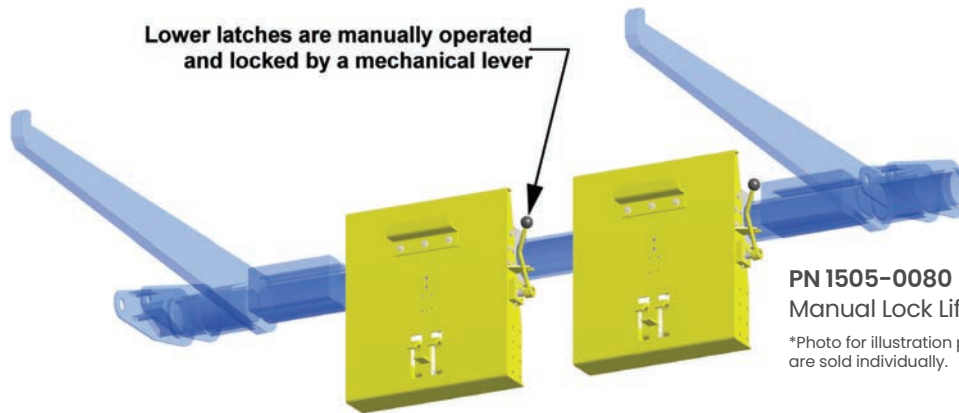

PN 1505-0080
Manual Lock Lifter

*Photo for illustration purposes. FEL Fork-Tube Lifters are sold individually.

FEL Fork-Tube Lifter Series - Pneumatically Operated Version

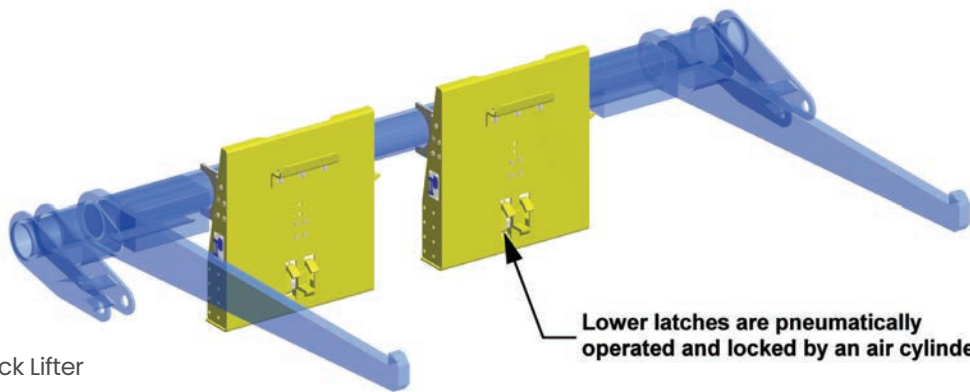

PN 1905-0080
Cylinder Hook Lock Lifter

*Photo for illustration purposes. FEL Fork-Tube Lifters are sold individually.

PERFORMANCE SPECIFICATIONS	
Cart Compatibility	ANSI Z 245.60-1996 Type B carts (domestic style 2-bar)
Lift Capacity	400 lbs.
Finish	Safety yellow powder-coating

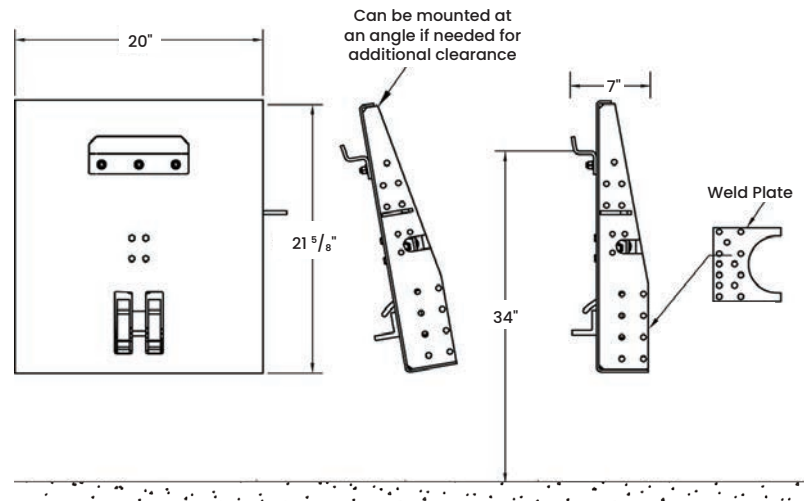

Pictures and mechanical diagrams in this literature are illustrative only and may not be to scale. Specifications are subject to change without notice in order to accommodate improvements to the equipment. Data published herein is for information purposes only and shall not be construed to warrant suitability of the unit for any particular purpose, as performance may vary with the conditions encountered. The only warranty is our standard written Warranty Statement for this product at the time of shipment.



Premium Lift Systems

Toll Free: 800-528-5308 | www.baynethinline.com

Bayne Thinline Premium Lift Systems | 4301 Gault Ave. North | Fort Payne, AL 35967

© Copyright 2023 Bayne Thinline All rights reserved

