

# M440 Compactor Unit

Specifications and Dimensions

<b>Cart Compatibility:</b>	ANSI Z245.60-1996 Type B Carts (domestic style 2-bar)
<b>Lift Capacity:</b>	1000 lbs @ 1500 psi
<b>Hydraulic Pressures:</b>	Working Pressure - 1500 psi Maximum Pressure - 2500 psi
<b>Hydraulic Flow:</b>	2.5 gpm
<b>Cycle Time:</b>	15 seconds
<b>Lubrication:</b>	Greasable "Zerks"
<b>Cylinder:</b>	Heavy-Duty Tie Rod Cylinder 3" Bore x 8" Stroke
<b>Finish:</b>	Gray Primer
<b>Options:</b>	<ul style="list-style-type: none"> <li>▪ Mounting Kit for Bolt-On Applications</li> <li>▪ Feed Chute</li> <li>▪ Flow Control Kit</li> <li>▪ Hydraulic Power Unit / Tap-In Kit</li> </ul>

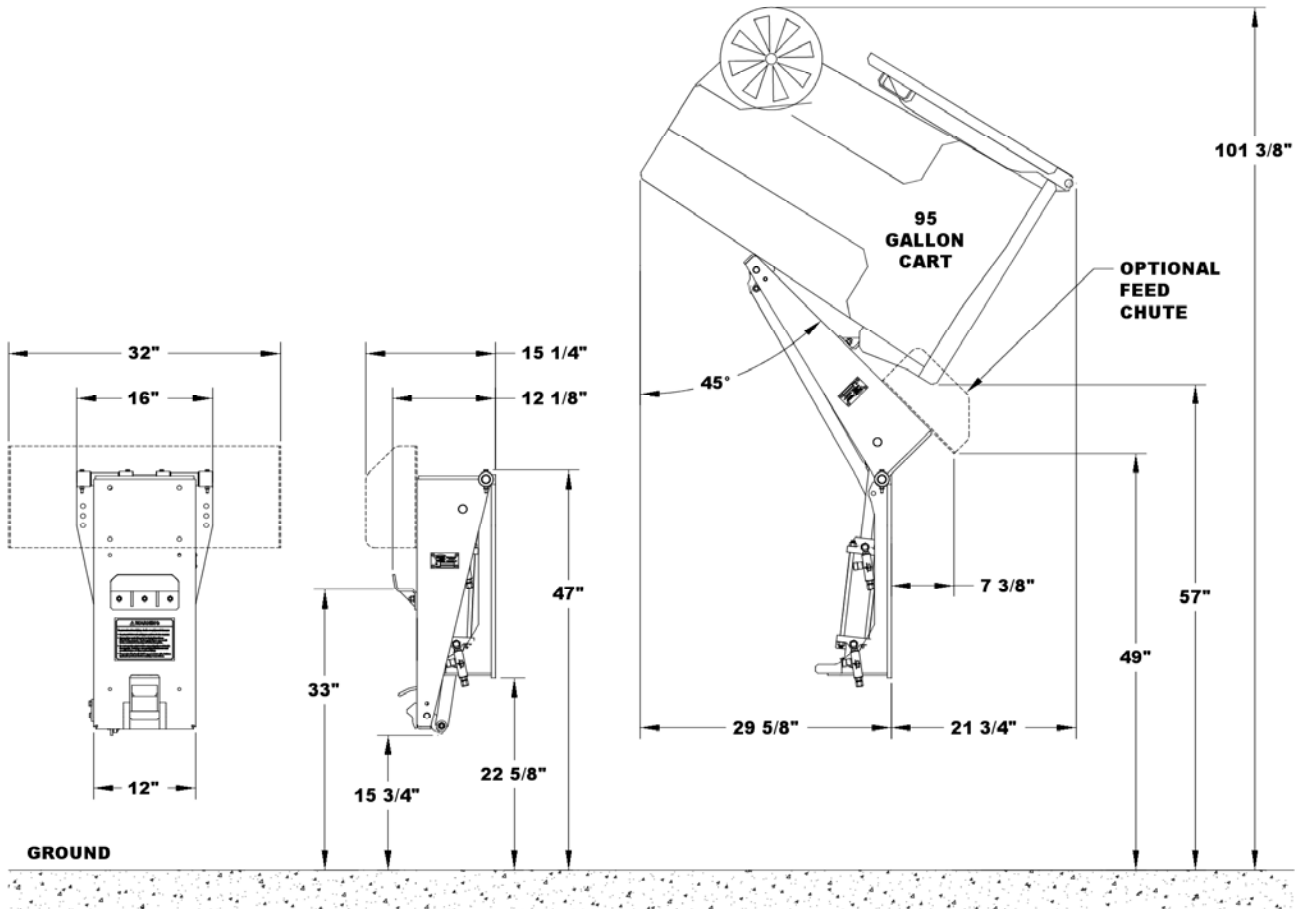

## Bayne Premium Lift Systems

910 Fork Shoals Road, Greenville, SC 29605 • [www.baynethinline.com](http://www.baynethinline.com)

Toll Free: 800.535.2671 • Local: 864.288.3877 • Fax: 864.458.7519