

Cart Lifter General Operation Guidelines

Always adhere to your company's safety guidelines when using this lifter. This includes wearing appropriate clothing and personal protective equipment, including reflective gear. Keep in mind that you are operating the lifter on public roads or alleys with moving traffic. Stay vigilant and watch out for vehicles and pedestrians.

The lifter should only be used for lifting ANSI-approved carts that are in good condition. It is not designed to be used as a step, to assist in lifting commercial containers, or to crush or break down items. Use with non-approved carts or misuse can result in serious injury or damage and will void the warranty.

Make sure the area around the lifter is free of personnel before operation. Always maintain a safe distance from the lifter to avoid pinch points that can cause serious injury.

Cart lifters can hang very low to the ground at certain points in the lift cycle. It is the operator's responsibility to move the lifter to a safe position, such as raising the lifter fully or placing the lifter in the storage position before driving. Lifters left hanging low risk bottoming out on the street, road, or alley. This can cause serious damage. Damages from bottoming out are not covered by the warranty.

It is the operator's responsibility to position the cart lifter safely before approaching any obstacles. Damages from collisions are not covered by the warranty.

TABLE OF CONTENTS

	Page
I. THINLINE [®] Safety _____	3
II. THINLINE [®] Specifications _____	4
III. THINLINE [®] Installation Instructions _____	5
IV. THINLINE [®] Operation Instructions _____	6
V. THINLINE [®] Maintenance Instructions _____	9
VI. Trouble-shooting Chart _____	10
VII. Appendix A	
1. Unit Assembly Drawing _____	13
2. Mounting Height Drawing _____	14
3. Optional Chute Assembly _____	15
4. Optional Mounting Plate Kit _____	16
5. Optional Flow Control Kit _____	17

SAFETY (WI-0070-A)
Bayne *THINLINE*[®] Premium Lift Systems

To prevent serious injury, death or equipment damage, read and understand this entire manual before installing, operating, repairing or adjusting your Bayne THINLINE[®] Premium Lift System. Those using and maintaining this equipment must be thoroughly trained and familiar with the product.

I. Manual:

This manual must be kept in a location that is readily available for those who operate or maintain this equipment. Additional copies may be obtained from your local dealer or directly from Bayne THINLINE[®] Premium Lift Systems.

II. Lockout/Tagout Procedures:

All applicable OSHA lockout/tagout regulations must be followed when working on this equipment. Failure to comply with these procedures can result in serious injury or death.

III. Safety Decals:

Safety decals attached to your Bayne THINLINE[®] Premium Lift System warn of hazards related to the use of this equipment. Operators must read and follow all safety instructions while using this equipment. If the safety decals are not clearly readable, new decals may be obtained from your local dealer or directly from Bayne THINLINE[®] Premium Lift Systems.

SPECIFICATIONS (WI-0501-A)
Bayne *THINLINE*[®] Premium Lift Systems

- A. Double acting cylinder.
 - Replaceable seals.
 - Double action provides smooth operation throughout the dump cycle.
- B. Main pivot points are supplied with grease fittings for extended life.
- C. The lift unit measures only 12-1/8” thick in the down position.
- D. The faceplate is normally at 45 degrees in the dump position in order to completely eject all materials into the hopper.
- E. The lift unit operates at a cycle time of **15 seconds** for safe, fast, efficient service.

Note : Cycle time is controlled by flowrate, as flowrate increases, cycle time decreases. In order to avoid injury and maintain manufacturer’s warranty never operate outside the cycle time listed above

- F. Recommended flow rate is **2.5 GPM**.
- G. Hydraulic pressure requirements are as follows:
 - **1500 PSI** normal working pressure
 - **2500 PSI** maximum pressure
- H. Lift unit can be a bolt on type installation for easy, quick maintenance and less downtime.
- I. All parts are manufactured and kept in stock at Bayne Machine Works, Inc. for fast response to customer requests.
- J. One (1) year limited warranty from date of delivery on all units and models when properly maintained and operated within the recommended cycle time.

All lift units and parts are inspected by our Quality Control Department before shipment to insure that you always receive the highest quality available in the lift business.

For more information, please contact us at (800) 535-2671 or by fax at (864) 458-7519.

INSTALLATION INSTRUCTIONS (WI-0251-A)

Bayne *THINLINE*[®] Premium Lift Systems

The following information is intended to be a **GENERAL GUIDE** to installing the Bayne *THINLINE*[®] lifter on a typical refuse truck. Before starting the installation, read these instructions completely. **ALWAYS** use the proper tools, lift devices, and personal protective equipment to prevent injury while performing the installation.

NOTE: If a Bayne *THINLINE*[®] Tap-In Kit was also acquired for this installation, refer to the installation instructions included in the Tap-In Kit manual for hydraulic information.

IV. Mounting lifter on the compactor :

1. The compactor should be emptied and cleaned before any installation. The compactor should be placed on a level solid surface, a concrete pad if possible.
2. All wiring, hydraulic lines, steps, etc. that will interfere with the installation should be removed and/or relocated.
3. Position the lifter on the side of the compactor per *figure I-1* and mounting height drawing (*Appendix A*) and weld in place. If installing with the use of a mounting plate kit for bolt-on applications, weld the mounting plate in place and attach the lifter using the studs, washers, and nuts supplied.

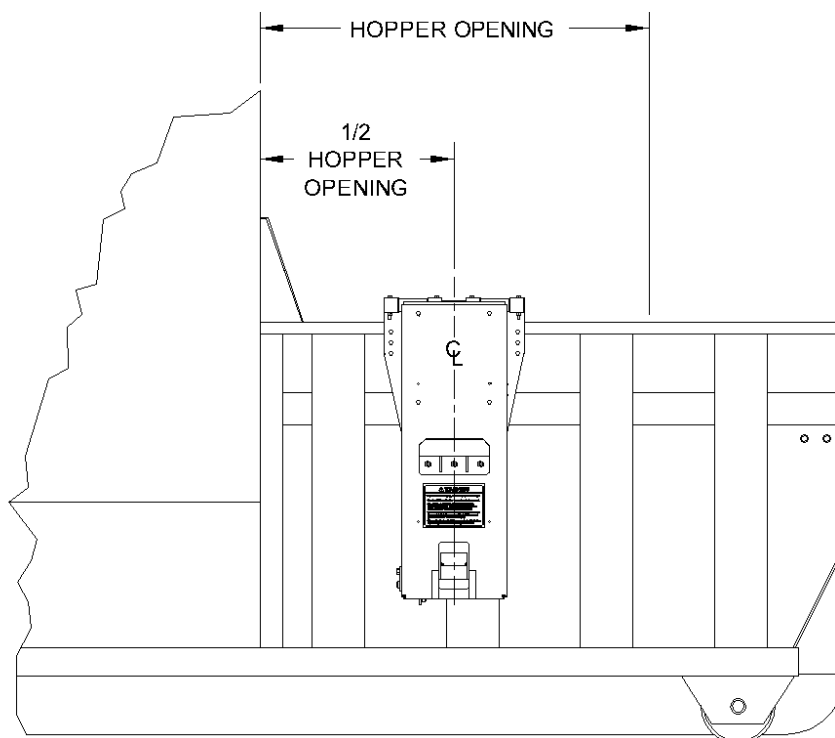

figure I-1

OPERATION INSTRUCTIONS (WI-0138-C)

Bayne *THINLINE*[®] Premium Lift Systems

The Bayne *THINLINE*[®] Premium Lift System is a high quality durable dumper built to meet industry requirements. To insure the safety of all operators of this equipment, please read this manual carefully before operating the dumper. *FAILURE TO COMPLY WITH INSTRUCTIONS COULD RESULT IN PERSONAL INJURY AND/OR PROPERTY DAMAGE.*

The operating stages (figure O-1) in the cycle of the dumper are as follows:

- 1) **START** - The container to be dumped is placed on the lift saddle.
- 2) **DUMP** - The hydraulic cylinder extends to dump the contents of the container into the hopper. During this cycle, the lower rotating hook automatically “locks” the container to the lifter.
- 3) **RETRACT** - The hydraulic cylinder retracts to return the container to the start position. The lower rotating hook automatically retracts to “unlock” the container from the dumper.

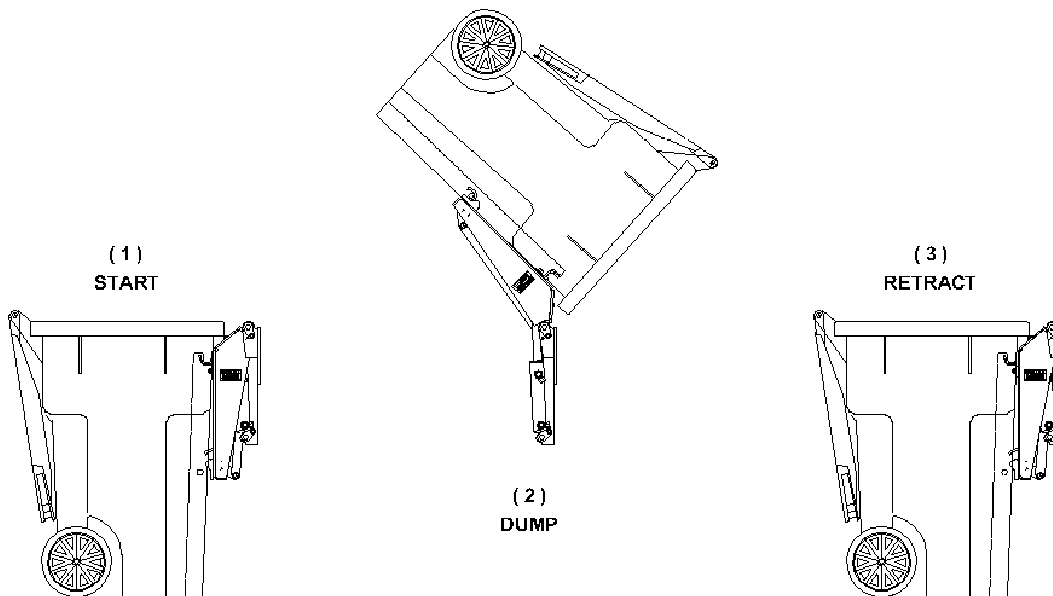

figure O-1

Warning: Exceeding the recommended cycle time on any dumper will void the manufacturer’s warranty

The rotational motions of the dumper are controlled with the use of a hand valve. Moving the handle on the hand valve in one direction will cause the dumper to perform the “dump” stage (figure O-1). Moving the handle in the opposite direction will cause the dumper to perform the retract stage.

SAFETY ZONES

Stand Clear Zone

To prevent serious injury or death, operators and bystanders should remain outside the Stand Clear Zone (figure O-2) at all times during the operating cycle of the lifter. If at any point during the cycle persons enter this area, the operator must stop all motion of the lifter until the area is cleared.

Dump Zone

To prevent serious injury or death, operators and bystanders should remain outside the Dump Zone (figure O-2) at all times. If it becomes necessary to enter this area, all applicable OSHA lockout/tagout regulations must be followed.

Operator Area

To provide a clear, unobstructed view of both the Stand Clear Zone and Dump Zone, operators should remain within the Operator Area (figure O-2) at all times during the operating cycle of the lifter.

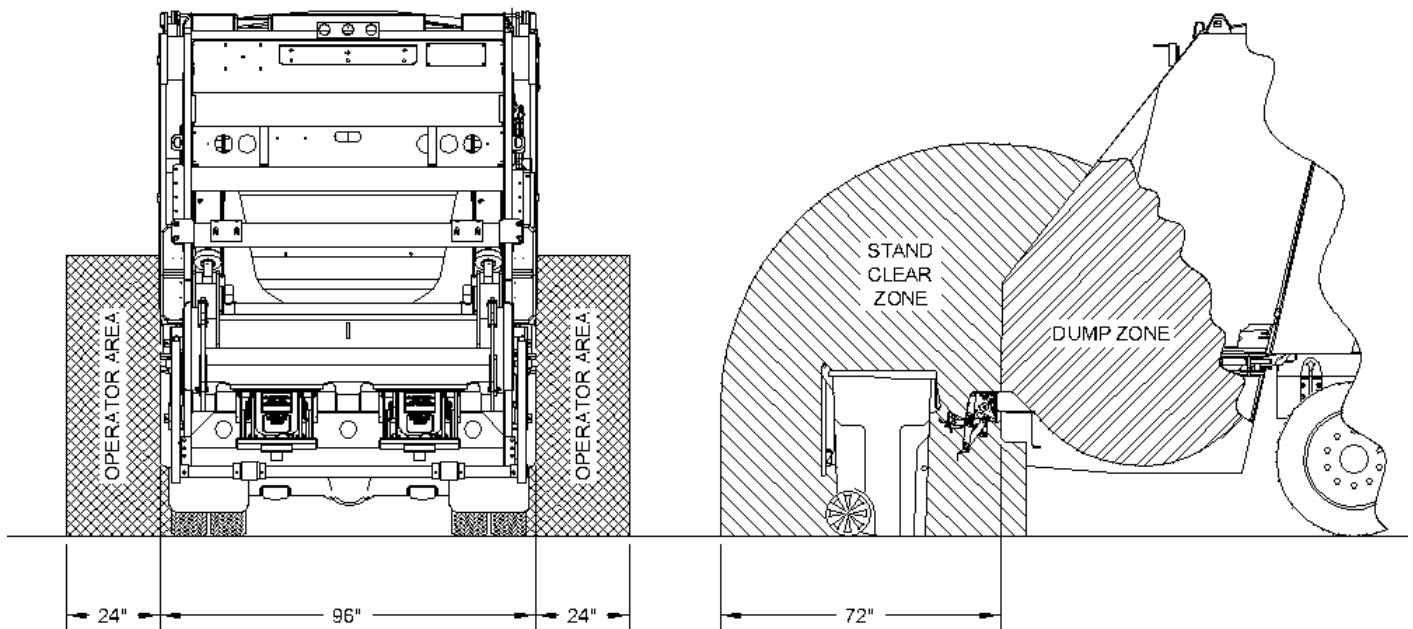

figure O-2

LOWER HOOK ADJUSTMENT

The lower hook is equipped with two settings that must be properly adjusted to accommodate the carts being lifted. Check the distance (**A**) (figure O-3) between the upper bar and the lower bar on the cart. If this dimension is between **15" to 15-1/2"**, leave the lower hook attachment in the lower setting. If this dimension is between **14-1/2" to 15"**, move the lower hook attachment to the upper setting.

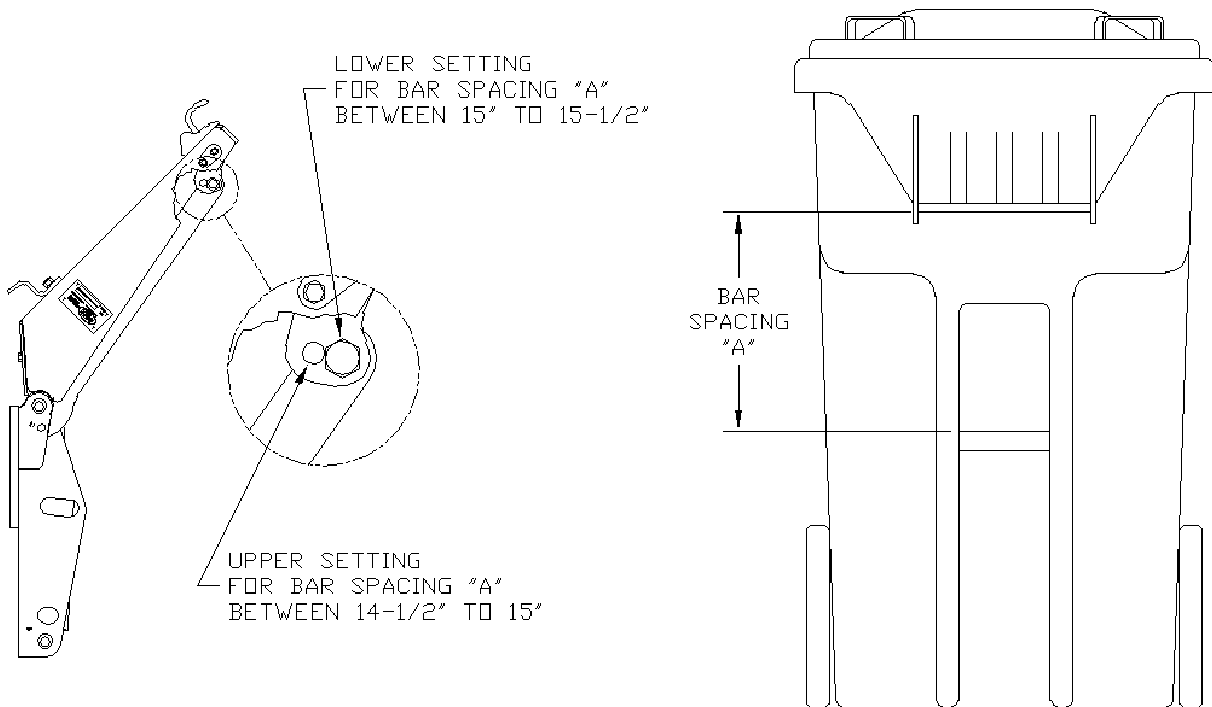

figure O-3

CAUTION: It is the responsibility of the owner / operator of this equipment to adjust these dimensions to be compatible with his specific application. If the bar spacing is not within either of the specified ranges, please contact us on available options for non-standard carts.

MAINTENANCE INSTRUCTIONS (WI-0141-A)
Bayne THINLINE[®] Premium Lift Systems

NOTE:

The most common cause of hydraulic component failure is contamination of the hydraulic fluid (water, chips, dirt, etc.) The Bayne *THINLINE*[®] Lift System comes clean from the factory. If removed, be sure the hoses, cylinder and fittings are clean before re-installing them on the unit.

Inspect your dumper on a weekly basis for loose bolts, fittings, oil leaks, etc. Tighten loose hardware as necessary and replace necessary seals to repair oil leaks.

TROUBLE-SHOOTING CHART (WI-0329-A)

<i>SYMPTOM</i>	<i>POSSIBLE CAUSES</i>	<i>CORRECTIVE ACTION</i>
Lifter operation very erratic.	<ol style="list-style-type: none"> 1. Air trapped in system. 2. Low oil level. 3. Flow control valves not set properly. 	<ol style="list-style-type: none"> 1. Bleed all air from lifter hydraulic system. 2. Add oil to system. 3. Adjust flow control valves attached to lift cylinder.
Cart lifter will not pick up carts.	<ol style="list-style-type: none"> 1. Cart overweight. 2. Hydraulic pressure too low. 3. Faulty hand valve. 	<ol style="list-style-type: none"> 1. Reduce loaded weight of cart. 2. Check and adjust pressure relief settings. 3. Replace hand valve.
Lifter operates extremely slow.	<ol style="list-style-type: none"> 1. Faulty hand valve. 2. Faulty hydraulic pump. 3. Flow control valves not set properly. 	<ol style="list-style-type: none"> 1. Replace hand valve. 2. Consult compactor maintenance manual. 3. Adjust flow control valves attached to lift cylinder.
Lifter operates under recommended cycle time.	<ol style="list-style-type: none"> 1. Flow control valves not set properly. 	<ol style="list-style-type: none"> 1. Adjust flow control valves attached to lift cylinder.

TROUBLE-SHOOTING CHART (WI-0329-A)

<i>SYMPTOM</i>	<i>POSSIBLE CAUSES</i>	<i>CORRECTIVE ACTION</i>
Cylinder leaking oil around rod.	1. Worn cylinder rod seals.	1. Install cylinder seal kit.
Lower hook frequently breaking or bending.	1. Lower hook not adjusted properly. 2. Bars on carts are not standard spread dimensions.	1. Adjust lower hook per Operation Instructions of this manual. 2. Replace cart or install new bars.
Lifter loses cart when dumping.	1. Lower hook not adjusted properly. 2. Bars on carts are not standard spread dimensions. 3. Lift bars on cart are bent or spread apart.	1. Adjust lower hook per Operation Instructions of this manual. 2. Replace cart or install new bars. 3. Replace cart or install new bars.
Lift bars on cart are being spread apart or damaged.	1. Lower hook not adjusted properly. 2. Bars on carts are not standard spread dimensions.	1. Adjust lower hook per Operation Instructions of this manual. 2. Replace cart or install new bars.

APPENDIX A
Assembly drawings and part numbers

1 2 3 4 5 6 7 8

PARTS LIST			
ITE	PART NO.	DESCRIPTION	QTY
1	4900-4000	M440 FACEPLATE WELDMENT	1
2	4900-4010	MAINFRAME WELDMENT	1
3	4900-4020	HOOK WELDMENT	1
4	4900-4025	FACEPLATE PIN	2
5	4900-4026	HOOK PIN WELDMENT	1
6	4900-4030	SADDLE WELDMENT	1
7	4900-4035	M440 HOOK DRIVE	1
8	2603-1401	SLEEVE BUSHING - .75 ID, .86 OD, .38 W	2
9	2603-1402	LINK SLEEVE	3
10	3024-1008	TIE ROD CYLINDER (3 BORE x 8 STROKE)	1
11	5000-0010	WARNING LABEL	1
12	7004-0300	3/16 STRAIGHT DRIVE GREASE FITTING	5
13	7500-0070	MODEL/SERIAL NAME PLATE	1
14	7500-0071	3/16 ALUMINUM DRIVE RIVET	1
15	8901-0400	1/4-20 ELASTIC LOCK NUT	4
16	9001-0420	1/4-20 x 2-1/2 HHCS	4
17	9001-0610	3/8-16 x 1-1/4 HHCS	4
18	9001-0812	1/2-13 x 1-1/2 HHCS	1
19	9001-0816	1/2-13 x 2 HHCS	1
20	9401-0600	3/8-16 HEX NUT	4
21	9521-0800	1/2-13 ELASTIC LOCK JAM NUT	2
22	9600-0500	5/16 FLAT WASHER	3
23	9600-0700	7/16 FLAT WASHER	4
24	9700-0600	3/8 LOCK WASHER	4
25	5000-0094	NOTICE LABEL	1

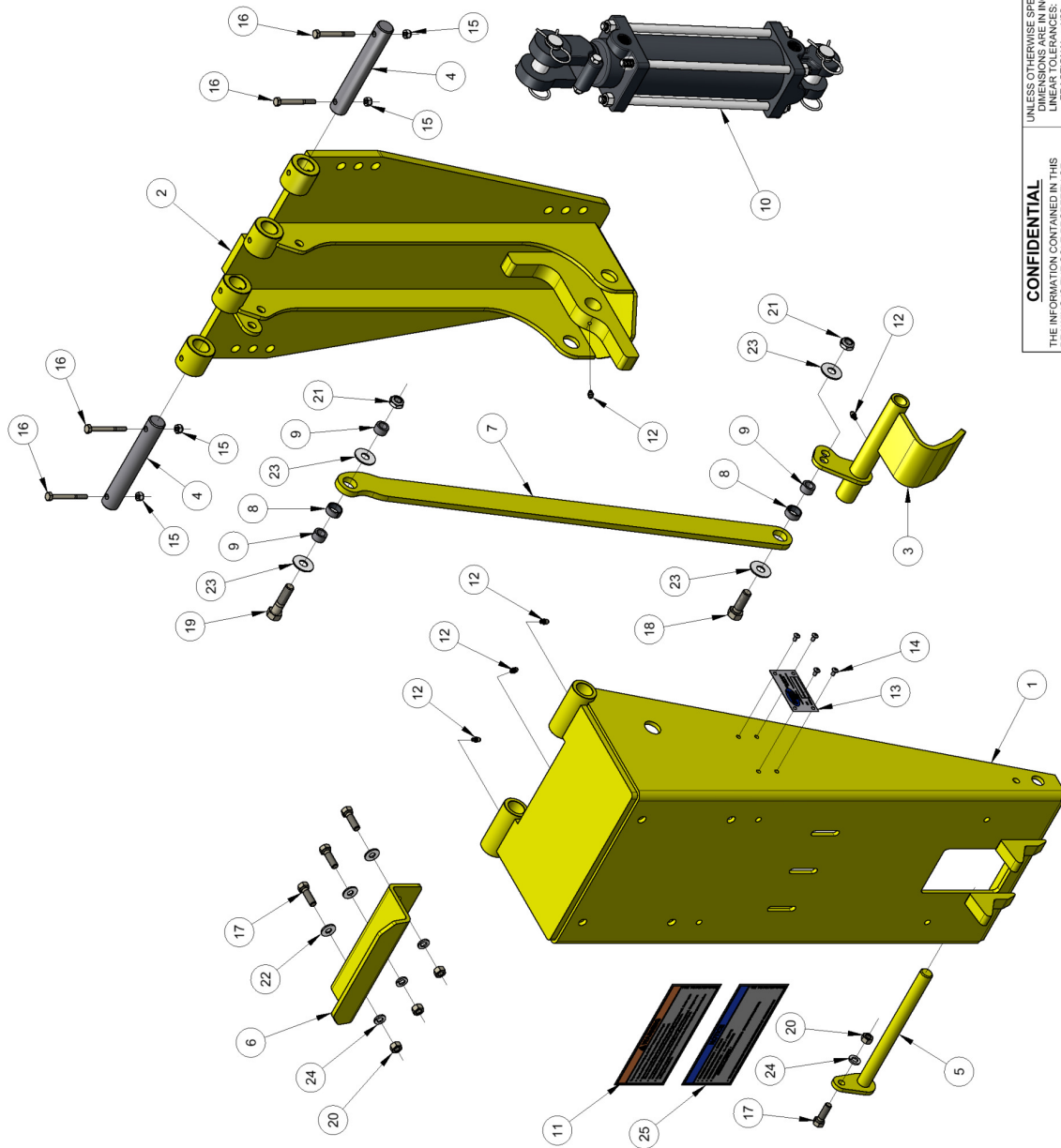

CONFIDENTIAL
 THE INFORMATION CONTAINED IN THIS DRAWING IS THE PROPERTY OF BAYNE MACHINE WORKS, INC. AND IS NOT TO BE COPIED OR USED IN ANY MANNER WITHOUT THE INTEREST OF BAYNE MACHINE WORKS, INC.

UNLESS OTHERWISE SPECIFIED DIMENSIONS ARE IN INCHES
 LINEAR TOLERANCES:
 FRACTIONS: ±.005
 DECIMALS: ±.015
 TWO PLACE DECIMAL: ±.015
 THREE PLACE DECIMAL: ±.005
 ANGULAR TOLERANCES:
 HOLE TO HOLE: ±.005 DEG
 HOLE TO CENTER: ±.005 DEG
 BEND: ±1.00 DEG

BAYNE MACHINE WORKS, INC.
 910 FORK SHOALS ROAD - GREENVILLE, SC 29605 - 864.288.3877

TITLE: **M440 LIFTER ASSEMBLY**

DRAWN BY	DATE	SCALE	SHEET	OF
CTT	2/17/2009	NONE	1	1
CHECKED BY	DATE	DWG NO	REV	
WTS	2/17/2009	1999-0440	B	

MATERIAL	WEIGHT	FINISH
	165.69 lbmass	

QTY	REV
	B

B	COLOR WAS GRAY PRIMER	2/9/2011	CTT	C1610	
A	ADDED 5000-0094	7/8/2010	CTT	C1965	
REV	DESCRIPTION	DATE	REV BY	CHK BY	ECR NO.

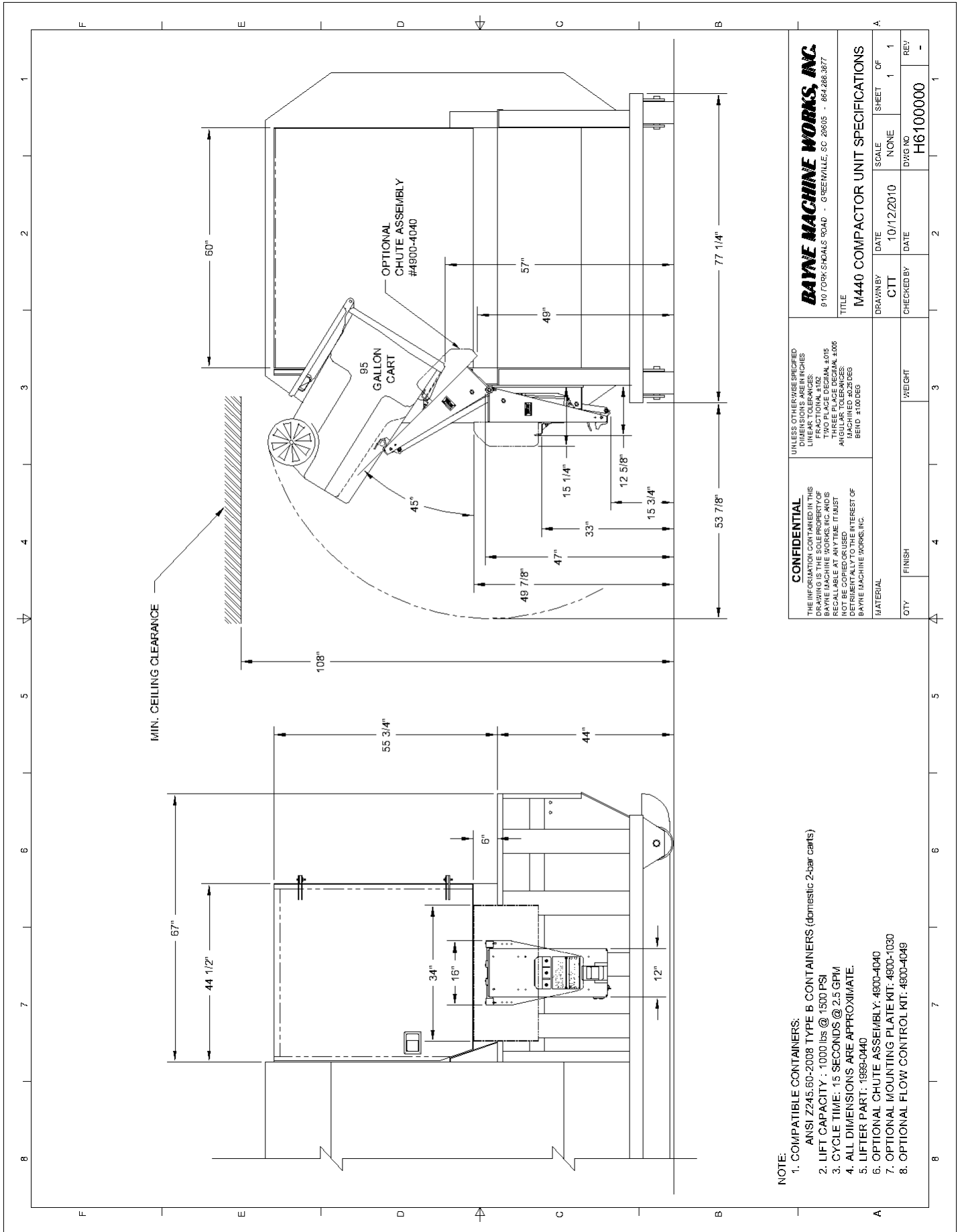

NOTE:

1. COMPATIBLE CONTAINERS: ANSI Z245.60-2008 TYPE B CONTAINERS (domestic 2-bar carts)
2. LIFT CAPACITY: 1000 lbs @ 1500 PSI
3. CYCLE TIME: 15 SECONDS @ 2.5 GPM
4. ALL DIMENSIONS ARE APPROXIMATE.
5. LIFTER PART: 1999-0440
6. OPTIONAL CHUTE ASSEMBLY: 4900-4040
7. OPTIONAL MOUNTING PLATE KIT: 4900-1030
8. OPTIONAL FLOW CONTROL KIT: 4900-4049

CONFIDENTIAL

THE INFORMATION CONTAINED IN THIS DOCUMENT IS UNCLASSIFIED EXCEPT WHERE SHOWN OTHERWISE. IT IS THE PROPERTY OF BAYNE MACHINE WORKS, INC. AND IS LOANED TO YOU BY BAYNE MACHINE WORKS, INC. IT IS NOT TO BE REPRODUCED OR TRANSMITTED IN ANY FORM OR BY ANY MEANS, ELECTRONIC OR MECHANICAL, INCLUDING PHOTOCOPYING, RECORDING, OR BY ANY INFORMATION STORAGE AND RETRIEVAL SYSTEM. BAYNE MACHINE WORKS, INC. BEND, #100 DEG

UNLESS OTHERWISE SPECIFIED DIMENSIONS ARE IN INCHES LINEAR TOLERANCES:

TWO PLACE DECIMAL, ±.015
THREE PLACE DECIMAL, ±.006
ALL DIMENSIONS ARE APPROXIMATE
BAYNE MACHINE WORKS, INC. BEND, #100 DEG

BAYNE MACHINE WORKS, INC.
910 YORK SHOALS ROAD - GREENVILLE, SC 29605 - 864.286.3877

TITLE
M440 COMPACTOR UNIT SPECIFICATIONS

DRAWN BY	DATE	SCALE	SHEET	OF
C/T	10/12/2010	NONE	1	1
CHECKED BY	DATE	WEIGHT	DWG NO	REV
			H6100000	-

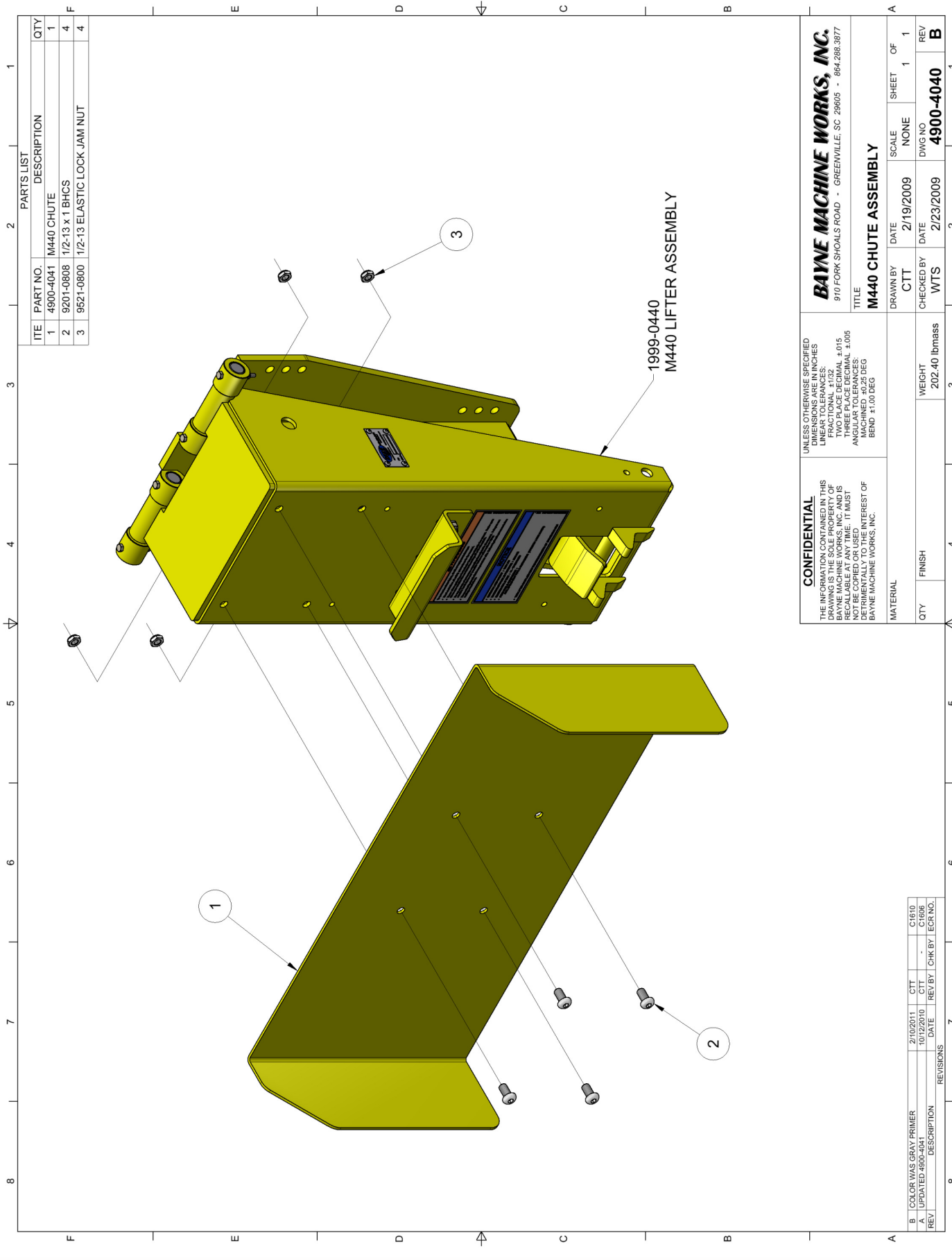

PARTS LIST			
ITE	PART NO.	DESCRIPTION	QTY
1	4900-4041	M440 CHUTE	1
2	9201-0808	1/2-13 x 1 BHCS	4
3	9521-0800	1/2-13 ELASTIC LOCK JAW NUT	4

CONFIDENTIAL
 THE INFORMATION CONTAINED IN THIS DRAWING IS THE PROPERTY OF BAYNE MACHINE WORKS, INC. AND IS NOT TO BE REPRODUCED OR TRANSMITTED IN ANY FORM OR BY ANY MEANS, ELECTRONIC OR MECHANICAL, INCLUDING PHOTOCOPYING, RECORDING, OR BY ANY INFORMATION STORAGE AND RETRIEVAL SYSTEM. WITHOUT THE WRITTEN PERMISSION OF BAYNE MACHINE WORKS, INC.

UNLESS OTHERWISE SPECIFIED DIMENSIONS ARE IN INCHES
 LINEAR TOLERANCES:
 FRACTIONS: ±.005
 DECIMALS: ±.005
 THREE PLACE DECIMAL: ±.015
 TWO PLACE DECIMAL: ±.005
 ANGLES: ±.005 DEGS
 HOLE TO LOCUS: ±.005 DEGS
 MACHINING: ±.005 DEGS
 BEND: ±1.00 DEGS

BAYNE MACHINE WORKS, INC.
 910 FORK SHOALS ROAD - GREENVILLE, SC 29605 - 864.288.3877

TITLE: **M440 CHUTE ASSEMBLY**

DRAWN BY	DATE	SCALE	SHEET	OF
CTT	2/19/2009	NONE	1	1
CHECKED BY	DATE	DWG NO	REV	
WTS	2/23/2009	4900-4040	B	

QTY	FINISH	WEIGHT
		202.40 lbmass

REV	DESCRIPTION	DATE	REV BY	CHK BY	ECR NO.
B	COLOR WAS GRAY PRIMER	2/10/2011	CTT		C1610
A	UPDATED 4900-4040	10/12/2010	CTT		C1608

ITEM	PART NO.	DESCRIPTION	QTY
1	4900-1001	MAINFRAME MOUNTING PLATE	1
2	9402-0800	1/2-20 HEX NUT	6
3	9700-0800	1/2" LOCK WASHER	6
4	9902-0814	1/2-20 x 1 3/4 STUD	6

NOTE:
 1. APPLY LOCTITE #271 (RED) TO 1/2-20 STUDS BEFORE THREADING INTO MOUNTING PLATE.

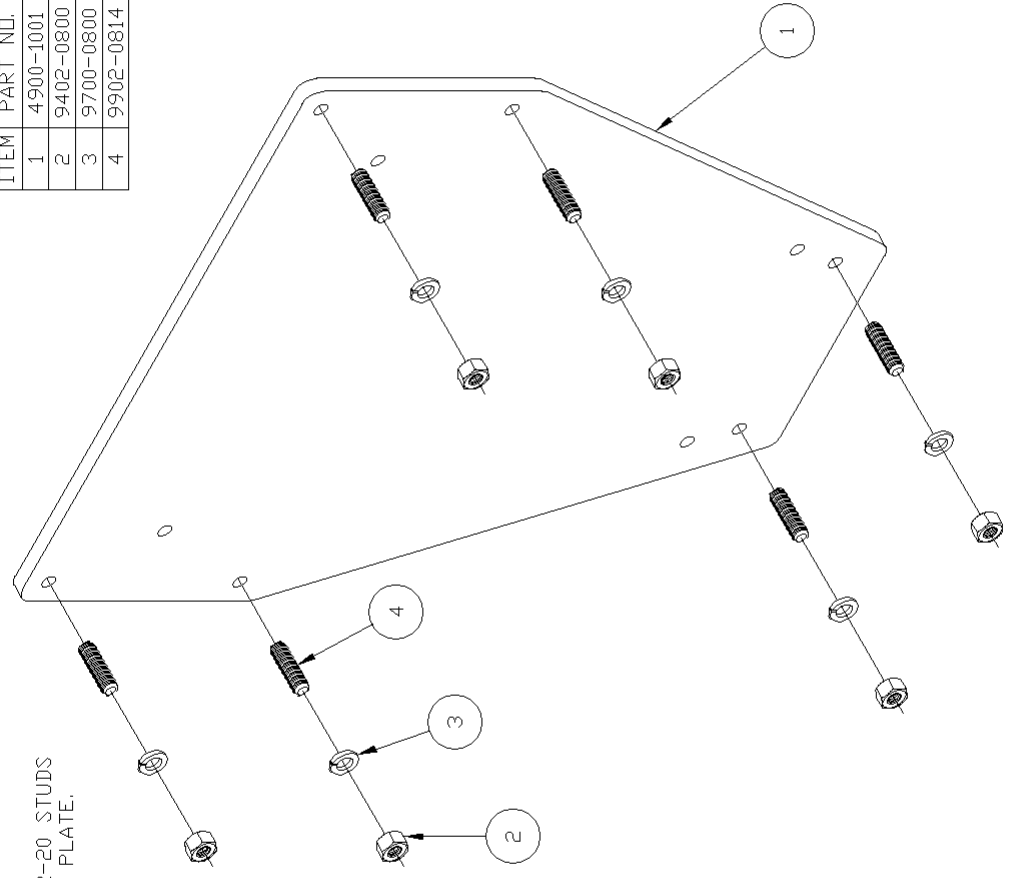

CONFIDENTIAL		This drawing is private and confidential communication and the property of BAYNE MACHINE WORKS, INC., Greenville, S.C. It MUST NOT be copied or lent without consent of BAYNE MACHINE WORKS, INC., and must be promptly returned with tender and/or completion of order to the purchasing department.		SCALE:	1=3	SHEET	1	OF	1	REV.	-
BAYNE MACHINE WORKS, INC. 910 FORK SHOALS ROAD - GREENVILLE, SC 29608 - 864.288.3877		DATE:	06/06/07	CHK'D BY:	CTT	DATE:	06/06/07	TITLE:	HI-LIFT MOUNTING PLATE KIT	DWG. NO.:	4900-1030

REFERENCE CYLINDER
PART # 3024-1008

PARTS LIST		QTY
ITEM	PART NO. DESCRIPTION	
1	6061-4031 ADJUSTABLE FLOW CONTROL	2
2	6201-0806 STRAIGHT ADAPTER (1/2 M-NPT x 3/8 M-JIC)	2
3	6220-0606 STRAIGHT FITTING (3/8 M-JIC x 3/8 M-SAE)	2
4	6248-0006 CAP NUT (3/8 F-JIC)	2
5	6265-0607 90 FITTING (3/8 F-JIC SWIVEL x 3/8 M-SAE)	2

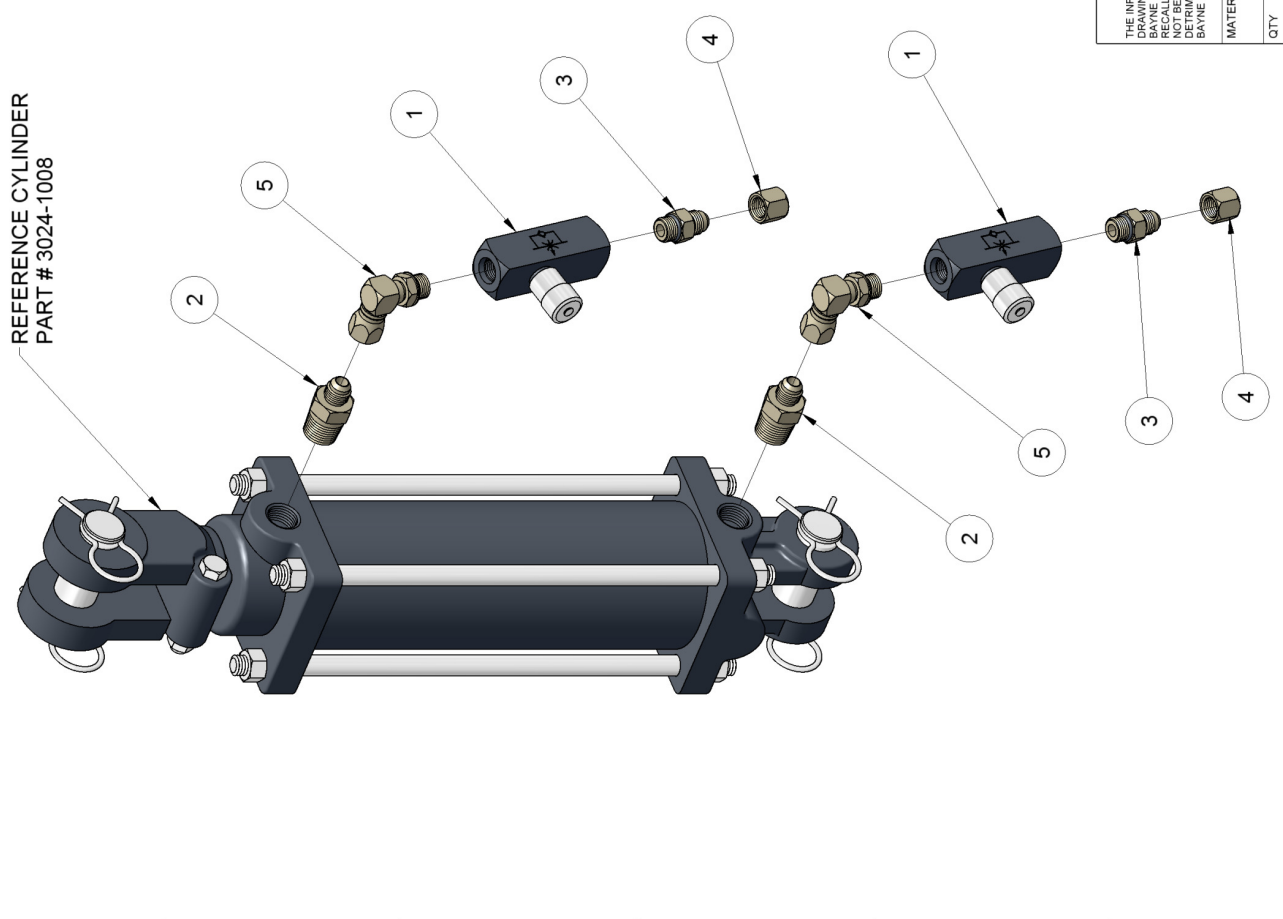

CONFIDENTIAL
THE INFORMATION CONTAINED IN THIS DRAWING IS THE PROPERTY OF BAYNE MACHINE WORKS, INC. AND IS NOT TO BE REPRODUCED OR USED IN ANY MANNER WITHOUT THE WRITTEN CONSENT OF BAYNE MACHINE WORKS, INC.

UNLESS OTHERWISE SPECIFIED DIMENSIONS ARE IN INCHES
LINEAR TOLERANCES:
ONE PLACE DECIMAL ±.015
TWO PLACE DECIMAL ±.010
THREE PLACE DECIMAL ±.005
ANGULAR TOLERANCES:
HOLE POSITION ±.005 INCHES
BEND ±1.00 DEG

BAYNE MACHINE WORKS, INC.
910 FORK SHOALS ROAD - GREENVILLE, SC 29605 - 864.288.3877

TITLE
M-SERIES FLOW CONTROL KIT

DRAWN BY	DATE	SCALE	SHEET	OF
CTT	4/1/2009	NONE	1	1
CHECKED BY	DATE	DWG NO	REV	
		4900-4049	-	

MATERIAL

QTY	FINISH	WEIGHT
		2.10 lbmass