



# TASKMASTER II

Mobile Refuse Cart Lifter

## Maximizing Route Safety & Efficiency

### Bayne Thinline Premium Lift Systems. Lifting Ergonomics To New Heights.

The Taskmaster II cylinder lift from Bayne® Thinline® Premium Lift Systems was designed for the hauler who is looking for an economical, quality-built cart lifter. In addition to collection vehicles, the Taskmaster II can be mounted on a stationary frame or compactor to offer a safety-conscious solution for a wide variety of material handling applications.

#### Taskmaster II Features:

- Compatible with standard domestic style 2-bar roll-out carts
- The Bayne Thinline design works in conjunction with most commercial container latch kits
- Break-away feature to minimize damage when properly mounted
- Solid hook-drive mechanism automatically secures the cart to the lift plate during the dump cycle
- Will not interfere with packer blade (when properly mounted)
- Self-lubricating composite bearings at all pivot points eliminate the need for greasing
- Powder-coated finish for durability
- 1-Year Limited Warranty



Premium Lift Systems

### Precision, Quality, and Patented Engineering

For more information: Toll Free: 800-528-5308 | [www.baynethinline.com](http://www.baynethinline.com)

Bayne Thinline Premium Lift Systems | 4301 Gault Ave. North | Fort Payne, AL 35967

# TASKMASTER II

## Specifications & Dimensions

PERFORMANCE SPECIFICATIONS	
Cart Compatibility	ANSI Z 245.60-2006 Type B Carts (domestic style 2-bar)
Lift Capacity	550 lbs. @ 1800 psi
Hydraulic Pressure	Working Pressure – 1800 psi Maximum Pressure – 2500 psi
Hydraulic Flow	2.0 – 2.5 gpm
Cycle Time	6 – 8 seconds
Bearings	Self-Lubricating Composite Material
Cylinder	Welded Construction 2.5" Bore x 6" Stroke
Finish	Safety yellow powder-coating
Options	Tap-in Kit
	Mounting-plate kit for bolt-on application



### How It Works:

The Taskmaster II was specifically designed to operate with the fewest moving parts possible, making it one of the most reliable lifters on the market. This unit specializes in lifting two-bar carts high into the hopper, emptying more trash per dump, all while saving fuel and lowering operating costs.

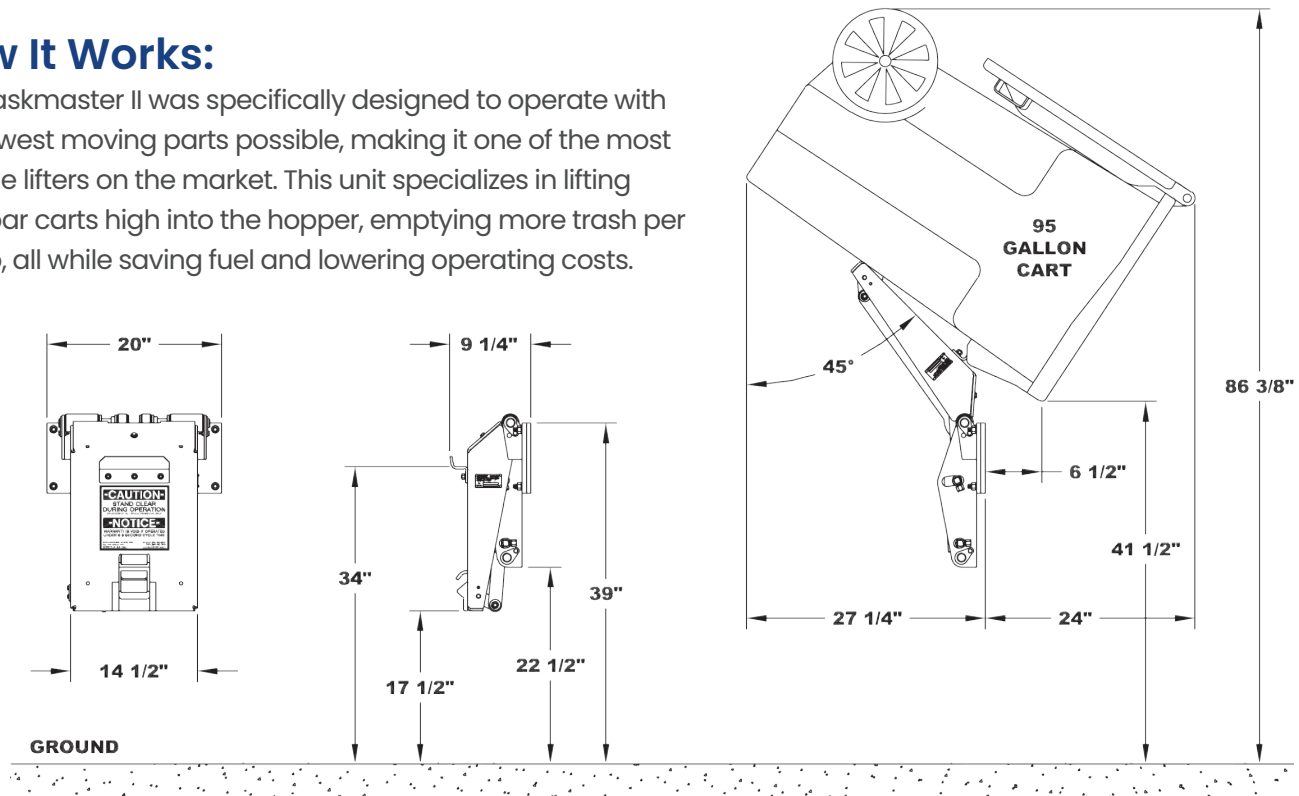

Pictures and mechanical diagrams in this literature are illustrative only and may not be to scale. Specifications are subject to change without notice in order to accommodate improvements to the equipment. Data published herein is for information purposes only and shall not be construed to warrant suitability of the unit for any particular purpose, as performance may vary with the conditions encountered. The only warranty is our standard written Warranty Statement for this product at the time of shipment.



Toll Free: 800-528-5308 | [www.baynethinline.com](http://www.baynethinline.com)

Bayne Thinline Premium Lift Systems | 4301 Gault Ave. North | Fort Payne, AL 35967

© Copyright 2023 Bayne Thinline All rights reserved



Premium Lift Systems