



# GRL SERIES

Mobile Refuse Cart Lifter

## Maximizing Route Safety & Efficiency.

### Bayne Thinline Premium Lift Systems. Lifting Ergonomics To New Heights.

The Grabber products are the most versatile series of lifters from Bayne® Thinline® Premium Lift Systems. These products were specifically designed for the hauler that handles a variety of different residential roll-out carts and large commercial containers on the same route. The GRL clamp-arm design is the first in the industry to not require the removal of the clamp arms in order to dump commercial containers. The GRL series is ideally suited for rear-load applications by providing an ample amount of ground clearance. This feature reduces the risk of damage to the lifter when used on uneven terrain, such as alley entrances, landfills, etc.

#### GRL Series Features:

- Powered by the patented Bayne Thinline rack-and-pinion rotary actuator for smooth operation
- Compatible with both semi-automated and fully automated roll-out carts
- Clamp arms do not have to be removed to dump commercial containers
- Measures only 7 1/8" thick in fully unclamped position
- 19" of ground clearance reduces the risk of damaging the lifter on uneven terrain
- Dumps cart higher and deeper inside the hopper opening to prevent spillage and increase route stops before needing to cycle the packer blade
- Self-lubricating composite bearings at main pivot points
- Powder-coated finish for durability
- 2-Year Limited Warranty



Premium Lift Systems

## Precision, Quality, and Patented Engineering

For more information: Toll Free: 800-528-5308 | [www.baynethinline.com](http://www.baynethinline.com)

Bayne Thinline Premium Lift Systems | 4301 Gault Ave. North | Fort Payne, AL 35967

# GRL SERIES

## Specifications & Dimensions

### PERFORMANCE SPECIFICATIONS

Cart Compatibility	ANSI Z245.60-1996 Type B Carts (domestic style 2-bar) ANSI Z245.60-1996 Type C Carts (European style) ANSI Z245.60-1996 Type D Carts (pocketed style) ANSI Z245.60-1996 Type G Carts (automated style) Standard size 30 and 55 gallon drums
Lift Capacity	400 lbs. @ 1800 psi
Hydraulic Pressure	Working Pressure – 1800 psi Maximum Pressure – 2500 psi
Hydraulic Flow	2.0 – 2.5 gpm
Cycle Time	10 – 12 seconds
Bearings	Self-Lubricating Composite Material
Actuator	Patented Bayne® Thinline® rack-and-pinion rotary actuator
Finish	Safety yellow powder-coating
Options	Tap-in Kit
	Mounting-plate kit for bolt-on application



### How It Works:

The patented Bayne Thinline design incorporates a sweeping action that automatically adjusts for uneven terrain, preventing operators from having to manually hoist carts onto the lift plate. The GRL Series was specifically designed to operate with the fewest moving parts possible, making it one of the most reliable lifters on the market. This lifter specializes in picking up two-bar carts high into the hopper, emptying more trash per dump, all while saving fuel and operating costs. The GRL Series also works with Rear Loaders that utilize a kick bar.

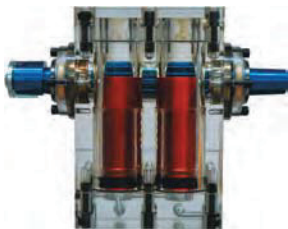

Patented Bayne Thinline  
Rack-and-Pinion Rotary  
Actuator

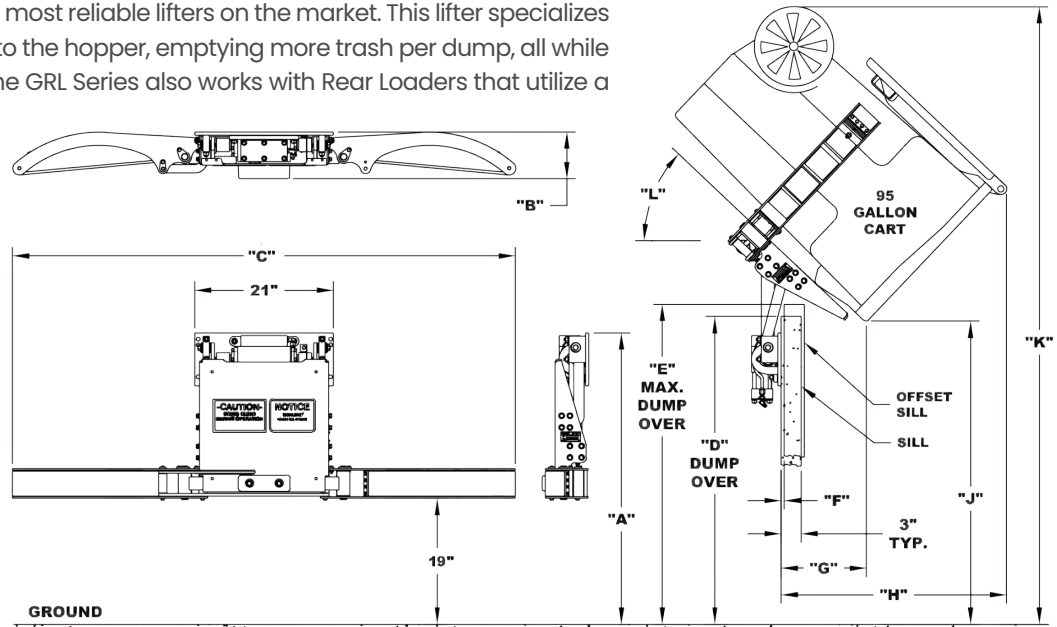

MODEL NUMBER	"A"	"B"	"C"	"D"	"E"	"F"	"G"	"H"	"J"	"K"	"L"
GRL 1110	40"	7 1/8"	76"	40 1/2"	N/A	N/A	12 7/8"	34"	37 3/4"	85 1/4"	43"
GRL 1112	42"	7 1/8"	76"	43 5/8"	44 3/4"	3/8"	13 1/4"	33 1/4"	42 5/8"	89 3/8"	40"
GRL 1114	44"	7 1/8"	76"	46 1/2"	48 1/4"	1/2"	12 7/8"	34"	45 3/4"	93 1/4"	43"
GRL 1120	50"	7 1/8"	76"	55 1/8"	60 3/4"	7/8"	12 3/4"	34"	57 1/2"	104 15/16"	45"
GRL 1128	58"	7 1/8"	76"	69 1/2"	73 5/8"	3/4"	12 3/4"	34"	73 1/2"	121 1/8"	44"

Pictures and mechanical diagrams in this literature are illustrative only and may not be to scale. Specifications are subject to change without notice in order to accommodate improvements to the equipment. Data published herein is for information purposes only and shall not be construed to warrant suitability of the unit for any particular purpose, as performance may vary with the conditions encountered. The only warranty is our standard written Warranty Statement for this product at the time of shipment.



Premium Lift Systems

Toll Free: 800-528-5308 | [www.baynethinline.com](http://www.baynethinline.com)

Bayne Thinline Premium Lift Systems | 4301 Gault Ave. North | Fort Payne, AL 35967

© Copyright 2023 Bayne Thinline All rights reserved

