

ETL-208

Mobile Refuse Cart Lifter



Maximizing Route Safety & Efficiency

Bayne Thinline Premium Lift Systems. Lifting Ergonomics To New Heights.

The ETL-208 Series is the newest line of cart tippers from Bayne® Thinline® Premium Lift Systems to lift and dump European-style carts. The ETL-208 safely holds and secures the European-style container using a finger-support bar and an automatically engaging clamp bar. The patent-pending design of the ETL-208 Series incorporates a sweeping action that automatically adjusts for uneven terrain, preventing operators from having to manually hoist carts onto the lifter pace-plate. This lifter was specifically designed to offer greater ground clearance for rear-load applications. The ETL-208 series is thin enough to work in conjunction with commercial container latch kits, thus allowing one truck to pick up both residential and commercial waste on the same route.

ETL-208 Features:

- Powered by the patented Bayne Thinline rack-and-pinion rotary actuator for smooth operation
- Compatible with standard European-style carts
- Over 20" of ground clearance reduces the risk of damaging the lifter on uneven terrain
- Sweeping motion for increased cart pick-up envelope
- Will not interfere with packer blade (when properly mounted)
- Dumps carts higher and deeper inside the hopper opening to prevent spillage and increase route stops before needing to cycle the packer blade
- Compact design works in conjunction with most commercial container lift bars
- Powder-coated finish for durability
- 2-Year Limited Warranty



Premium Lift Systems

Precision, Quality, and Patented Engineering

For more information: Toll Free: 800-528-5308 | www.baynethinline.com

Bayne Thinline Premium Lift Systems | 4301 Gault Ave. North | Fort Payne, AL 35967

PERFORMANCE SPECIFICATIONS

Cart Compatibility	ANSI Z245.60-208 Type C Containers (European-style carts)
Lift Capacity	400 lbs. @ 1,800 psi
Hydraulic Pressure	Maximum Pressure – 3,000 psi
Hydraulic Flow	2.0 – 2.5 gpm
Cycle Time	8 – 10 seconds
Bearings	Self-Lubricating Composite Material
Actuator	Patented Bayne® Thinline® rack-and-pinion rotary actuator
Finish	Safety yellow powder-coating
Options	Tap-in Kit
	Mounting-plate kit for bolt-on application



How It Works:

The Bayne Thinline patented design incorporates a sweeping action that automatically adjusts for uneven terrain, preventing operators from having to lift carts onto the lift plate. The ETL-208 was specifically designed to offer the most ground clearance possible for rear-load garbage truck applications.

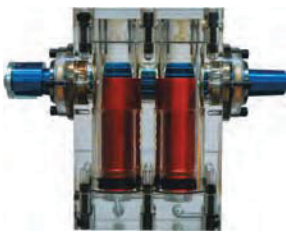

Patented Bayne Thinline Rack-and-Pinion Rotary Actuator

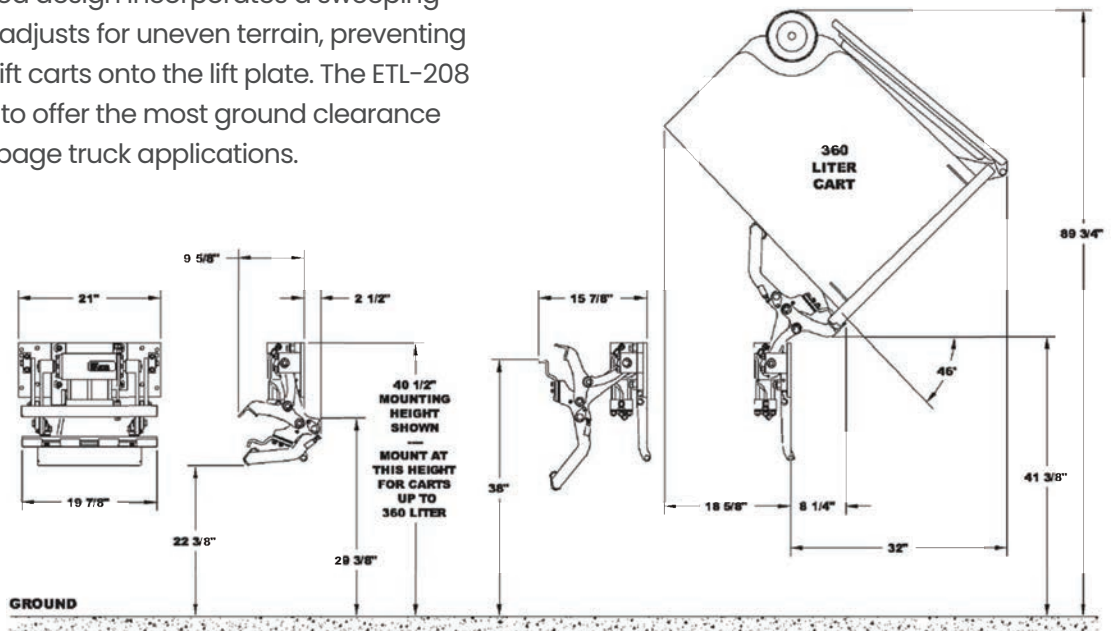

Pictures and mechanical diagrams in this literature are illustrative only and may not be to scale. Specifications are subject to change without notice in order to accommodate improvements to the equipment. Data published herein is for information purposes only and shall not be construed to warrant suitability of the unit for any particular purpose, as performance may vary with the conditions encountered. The only warranty is our standard written Warranty Statement for this product at the time of shipment.



Premium Lift Systems

Toll Free: 800-528-5308 | www.baynethinline.com

Bayne Thinline Premium Lift Systems | 4301 Gault Ave. North | Fort Payne, AL 35967

© Copyright 2023 Bayne Thinline All rights reserved

