



TaskmasterTM Series

Mobile Refuse Cart Lifter

The **Taskmaster** cylinder lift from *Bayne Premium Lift Systems* was designed for the hauler who is looking for an economical, quality-built cart lifter. In addition to collection vehicles, the Taskmaster can be mounted on a stationary frame or compactor to offer a safety conscious solution for a wide variety of material handling applications.

- Compatible with standard domestic style 2-bar roll-out carts
- The Thinline[®] design works in conjunction with most commercial container latch kits
- Break-away feature to minimize damage when properly mounted
- Solid hook drive mechanism automatically secures the cart to the lift plate during the dump cycle
- Welded cylinder with replaceable seals
- Will not interfere with packer blade
- Self-lubricating composite bearings at all pivot points eliminate the need for greasing
- Powder-coated finish for durability
- 1-Year Limited Warranty



Premium Lift Systems

Precision, Quality and...Patented Engineering!

Taskmaster™ Series *Specifications and Dimensions*

Cart Compatibility:	ANSI Z 245.60-2006 Type B Carts (domestic style 2-bar)
Lift Capacity:	550 lbs @ 1800 psi
Hydraulic Pressures:	Working Pressure – 1800 psi Maximum Pressure – 2500 psi
Hydraulic Flow:	2.0 – 2.5 gpm
Cycle Time:	6 – 8 seconds
Bearings:	Self-Lubricating Composite Material
Cylinder:	Welded Construction with Replaceable Seals 2.5" Bore x 6" Stroke
Finish:	Safety Yellow Powder Coating
Options:	<ul style="list-style-type: none"> • Tap-In-Kit • Mounting Plate Kit for Bolt-On Application • Commercial Container Bumper Kit

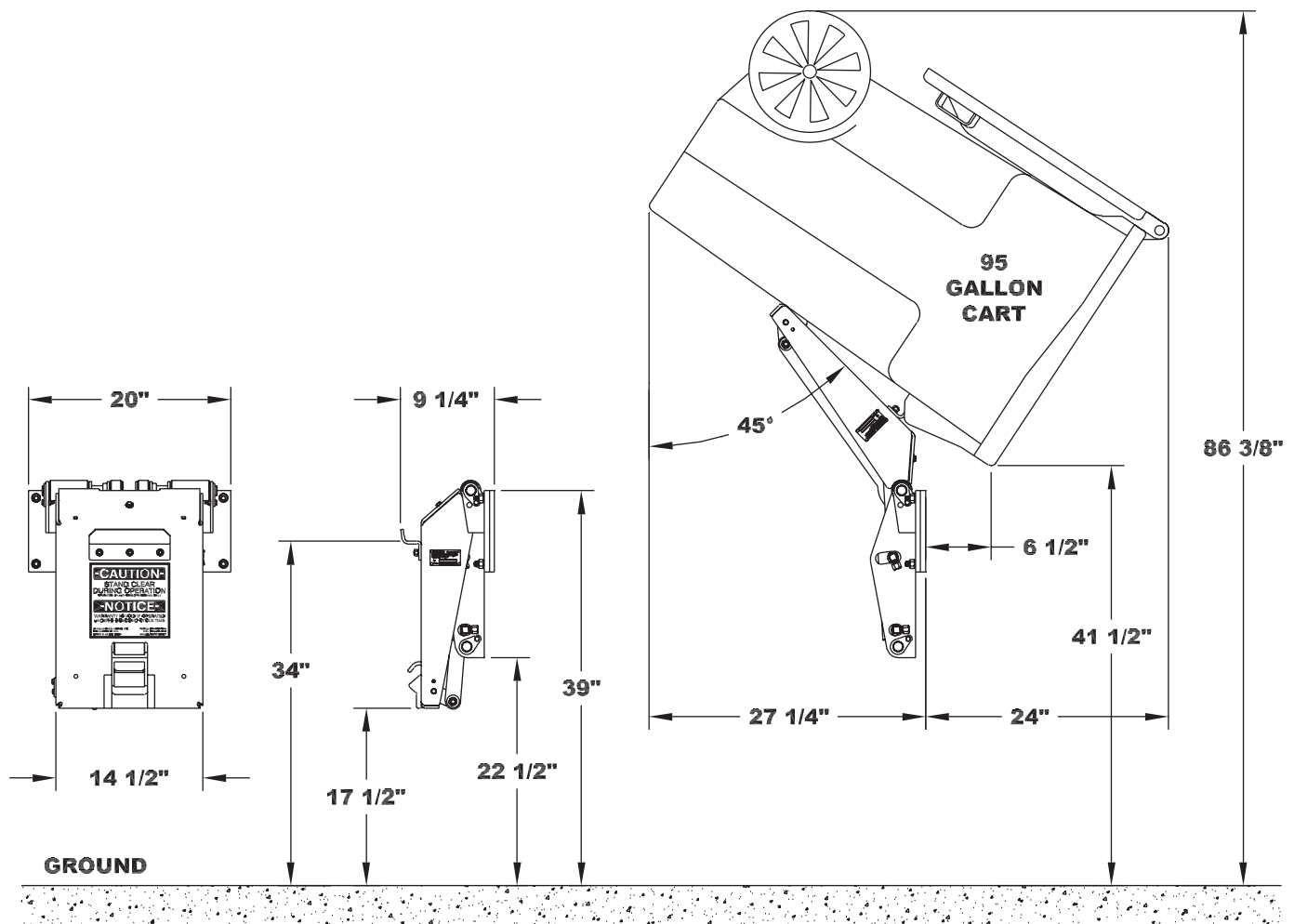

Bayne Premium Lift Systems

910 Fork Shoals Road, Greenville, SC 29605 • www.bayneonline.com
Toll Free: 800.535.2671 • Local: 864.288.3877 • Fax: 864.458.7519

© 2008, Bayne Premium Lift Systems
Printed in U.S.A. For #BLS-06-002-091808