

NOTE:

1. COMPATIBLE CONTAINERS:
ANSI Z245.60-2008 TYPE B CONTAINERS (domestic 2-bar carts)
2. LIFT CAPACITY: 550 lbs @ 1800 PSI
3. CYCLE TIME: 8 SECONDS @ 1.8 GPM
4. POWER UNIT: 5 HP MOTOR (460V three-phase)
1.8 GPM GEAR PUMP
4 GALLON OIL RESERVOIR
2500 PSI MAXIMUM PRESSURE
KEYED ON/OFF SWITCH
HAND HELD PENDENT CONTROL w/ 6' CORD
5. ALL DIMENSIONS ARE APPROXIMATE.

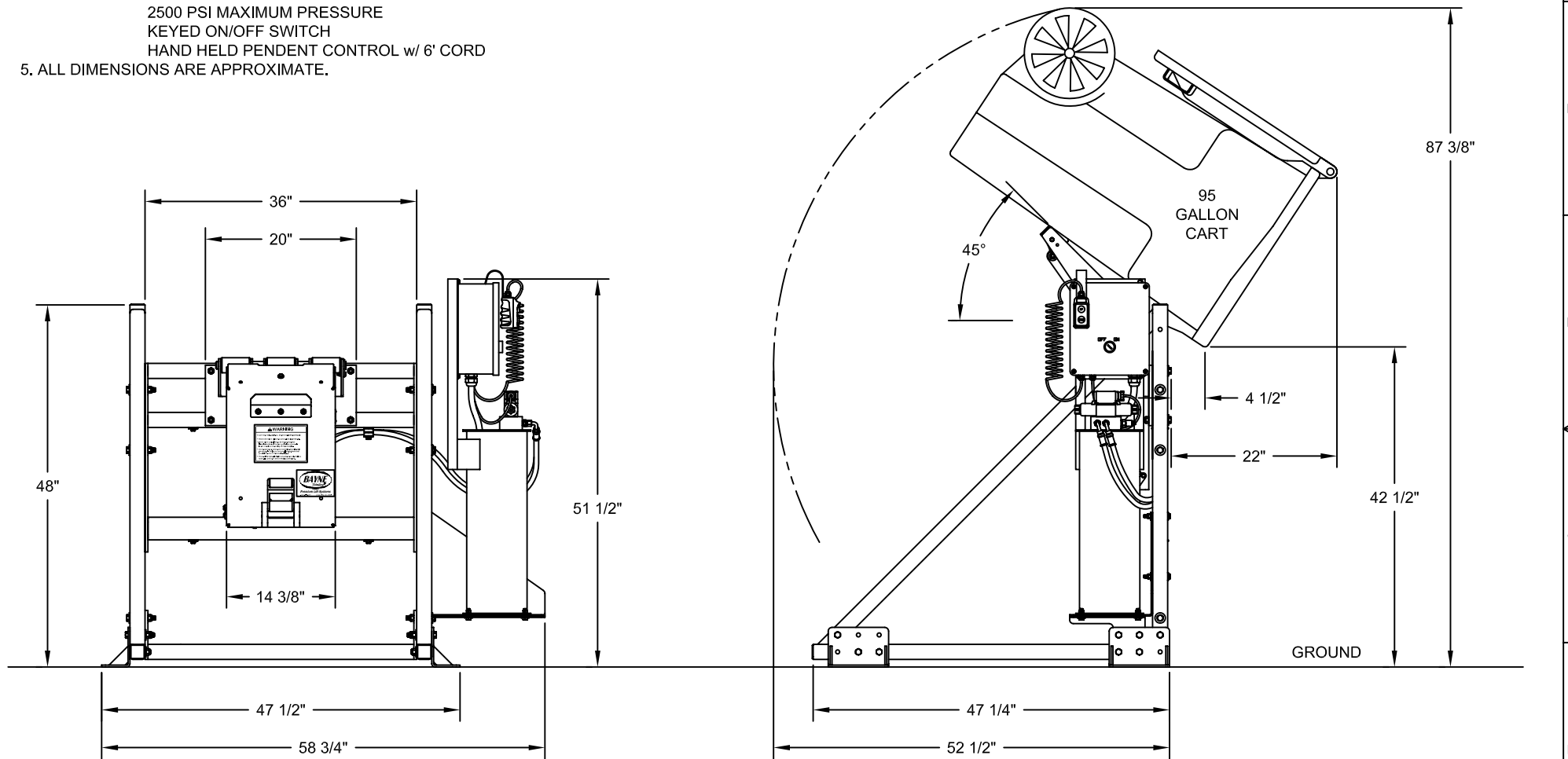

CUSTOMER APPROVAL DRAWING	
This drawing is private and confidential communication and the property of BAYNE MACHINE WORKS, INC., Greenville, S.C. It MUST NOT be copied or lent without consent of BAYNE MACHINE WORKS, INC.	SUBMITTED FOR YOUR APPROVAL
This drawing supersedes all drawings of previous issues. Destroy all drawings of this part number issued prior to this date:	This proposal drawing will not be released for production without a signed approval. Please review this drawing and the product shown carefully and mark all changes required.
05/13/2010	Name _____ Date _____ Title _____ Company _____

CONFIDENTIAL		UNLESS OTHERWISE SPECIFIED DIMENSIONS ARE IN INCHES LINEAR TOLERANCES: FRACTIONAL ±1/32 TWO PLACE DECIMAL ±.015 THREE PLACE DECIMAL ±.005 ANGULAR TOLERANCES: MACHINED ±0.25 DEG BEND ±1.00 DEG		BAYNE MACHINE WORKS, INC. 910 FORK SHOALS ROAD - GREENVILLE, SC 29605 - 864.288.3877	
THE INFORMATION CONTAINED IN THIS DRAWING IS THE SOLE PROPERTY OF BAYNE MACHINE WORKS, INC. AND IS RECALLABLE AT ANY TIME. IT MUST NOT BE COPIED OR USED DETRIMENTALLY TO THE INTEREST OF BAYNE MACHINE WORKS, INC.		TITLE TSKM-RGD-460-RHC SPECIFICATIONS			
MATERIAL		DRAWN BY	DATE	SCALE	SHEET OF
		CTT	05/13/2010	NONE	1 1
QTY	FINISH	WEIGHT	CHECKED BY	DATE	DWG NO
					H5800002
				REV	-