



LIFTING ERGONOMICS TO NEW HEIGHTS

Premium Lift Systems

# MBTL 180

## 1999-0180

OPERATION AND PARTS MANUAL

ISSUED FEBRUARY 2020

CUSTOMER NAME: \_\_\_\_\_

SERIAL NUMBER: \_\_\_\_\_

1999-0180 Revision No. 008

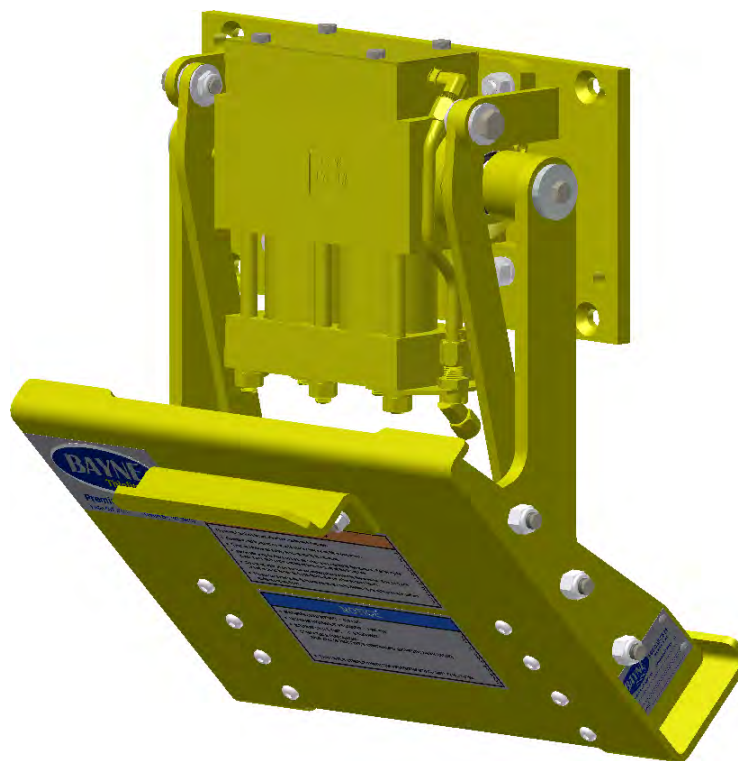

© 2020 Bayne Premium Lift Systems



Environmental Solutions Group  
201 W. Main Street, Ste 300  
Chattanooga, TN 37408  
Bayne Customer Care: 800.535.2671

# Cart Lifter General Operation Guidelines

Always adhere to your company's safety guidelines when using this lifter. This includes wearing appropriate clothing and personal protective equipment, including reflective gear. Keep in mind that you are operating the lifter on public roads or alleys with moving traffic. Stay vigilant and watch out for vehicles and pedestrians.

The lifter should only be used for lifting ANSI-approved carts that are in good condition. It is not designed to be used as a step, to assist in lifting commercial containers, or to crush or break down items. Use with non-approved carts or misuse can result in serious injury or damage and will void the warranty.

Make sure the area around the lifter is free of personnel before operation. Always maintain a safe distance from the lifter to avoid pinch points that can cause serious injury.

Cart lifters can hang very low to the ground at certain points in the lift cycle. It is the operator's responsibility to move the lifter to a safe position, such as raising the lifter fully or placing the lifter in the storage position before driving. Lifters left hanging low risk bottoming out on the street, road, or alley. This can cause serious damage. Damages from bottoming out are not covered by the warranty.

It is the operator's responsibility to position the cart lifter safely before approaching any obstacles. Damages from collisions are not covered by the warranty.



# WARNING

**IF INCORRECTLY USED, THIS EQUIPMENT CAN CAUSE SEVERE INJURY. THOSE WHO USE AND MAINTAIN THE EQUIPMENT SHOULD BE TRAINED IN ITS PROPER USE, WARNED OF ITS DANGERS, AND SHOULD READ AND FULLY UNDERSTAND THIS ENTIRE MANUAL BEFORE ATTEMPTING TO SET UP, OPERATE, ADJUST OR SERVICE THE EQUIPMENT. KEEP THIS MANUAL FOR FUTURE REFERENCE**

## IMPORTANT SAFETY NOTICE

Proper service and repair are important to the safe, reliable operation of the Bayne THINLINE® products. Service procedures recommended by Bayne THINLINE® are described in this Operation and Parts Manual and are effective for performing service operations. Some of these service operations may require the use of tools or blocking devices specially designed for the purpose. Special tools should be used when and as recommended. It is important to note that some warnings against the use of specific methods that can damage the product or render it unsafe are stated in the service manual. It is also important to understand these warnings are not exhaustive. Bayne THINLINE® could not possibly know, evaluate and advise the service trade of all conceivable ways in which service might be done or of the possible hazardous consequences of each method. Consequently, Bayne THINLINE® has not undertaken any such broad evaluations. Accordingly, anyone who uses service procedures or tools which are not recommended by Bayne THINLINE® must first satisfy himself thoroughly that neither his safety nor the product safety will be jeopardized by the method he selects.

# MBTL 180

## TABLE OF CONTENTS

Safety .....	2
Specifications .....	3
Installation Instructions .....	4
Operation Instructions .....	10
Diverter Valve Information .....	12
Maintenance Instructions .....	14
Actuator Assembly Instructions .....	15
Troubleshooting Chart .....	23
Appendix A - Assembly Drawings and Part Numbers .....	25
1999-0180 - MBTL 180 Lifter Assembly .....	26
4200-0049 - MBTL Faceplate Assembly .....	27
4200-0047 - MBTL Slider Latch .....	28
H5700003 - MBTL 180 Specifications .....	29
6900-0700 - Hydraulic Schematic .....	30
6900-0704 - Hydraulic Schematic .....	31
M3500005 - Single/Dual Diverter Valve Parts .....	32
8000-0780 - Diverter Valve Seal Kit .....	33
6083-1010 - Single Hand Valve with Bracket .....	34
8000-0085 - Hand Valve Seal Repair Kit .....	35
LUB4200 - MBTL Lubrication Points .....	36
<b>Index.....</b>	<b>37</b>

**MBTL 180**

**INTENTIONALLY LEFT BLANK**

**MBTL 180**

**PART NUMBER: 1999-0180 REVISION NO. 008**

**OPERATION AND PARTS MANUAL**

# MBTL 180

## Safety

### SAFETY

WI-0070-A

To prevent serious injury, death or equipment damage, read and understand this entire manual before installing, operating, repairing or adjusting your **Bayne THINLINE®** Premium Lift System. Those using and maintaining this equipment must be thoroughly trained and familiar with the product.

#### A. Manual:

This manual must be kept in a location that is readily available for those who operate or maintain this equipment. Additional copies may be obtained from your local dealer or directly from **Bayne THINLINE®** Premium Lift Systems.

#### B. Lockout/Tagout Procedures:

All applicable OSHA lockout/tagout regulations must be followed when working on this equipment. Failure to comply with these procedures can result in serious injury or death.

#### C. Safety Decals:

Safety decals attached to your **Bayne THINLINE®** Premium Lift System warn of hazards related to the use of this equipment. Operators must read and follow all safety instructions while using this equipment. If the safety decals are not clearly readable, new decals may be obtained from your local dealer or directly from **Bayne THINLINE®** Premium Lift Systems.

### SPECIFICATIONS

WI-0083-B

A. Rotary Actuator - rack and pinion style design.

- Rack, pinion, and shaft bearings are constantly lubricated by the hydraulic oil for extended life.
- Body and caps are made of high quality ductile iron.
- Pinion output shaft and racks are made of high tensile alloy steel.
- The rotary actuator provides smooth motion throughout the lift cycle, which results in longer cart life with virtually no cart damage or abuse.

B. The MBTL lift unit measures as little as 9 1/4" thick from the back of the mainframe to the front of the lift saddle in the down position. The MBTL lift unit also rotates underneath the hopper 45 degrees to allow for easy dumping of large commercial containers without interference.

C. The MBTL faceplate is normally at 45 degrees in the dump position in order to completely eject all materials into the hopper. The faceplate remains outside the hopper opening in the dump position, therefore preventing any interference with the sweep of the packer blade.

D. The MBTL lift unit operates at a cycle time of **6 to 8 seconds** for safe, fast, efficient service.

#### NOTICE

---

Cycle time is controlled by flowrate, as flowrate increases, cycle time decreases. In order to avoid injury and maintain manufacturer's warranty never operate outside the cycle time listed above

---

E. Recommended flow rate is **2 to 2 1/2 GPM**.

F. Hydraulic pressure requirements are as follows:

- **2000 to 2500 PSI** normal working pressure
- **3000 PSI** maximum pressure

G. MBTL lift units can be a bolt on type installation for easy, quick maintenance and less downtime.

H. All parts are manufactured and kept in stock at Bayne Machine Works, Inc. for fast response to customer requests.

I. One ( 1 ) year limited warranty from date of delivery on all units and models when properly maintained and operated within the recommended cycle time.

#### NOTICE

---

All lift units and parts are inspected by our Quality Control Department before shipment to insure that you always receive the highest quality available in the lift business.

---

For more information, please contact us at 800.535.2671 or by fax at 864.458.7519.



# MBTL 180

## Installation Instructions

### INSTALLATION INSTRUCTIONS

WI-0221-B

The following information is intended to be a **GENERAL GUIDE** to installing the **Bayne THINLINE®** lifter on a typical refuse truck. Before starting the installation, read these instructions completely. **ALWAYS** use the proper tools, lift devices, and personal protective equipment to prevent injury while performing the installation.

#### NOTICE

If a **Bayne THINLINE®** Tap-In Kit was also acquired for this installation, refer to the installation instructions included in the Tap-In Kit manual for more detailed information.

#### A. Mounting lifter(s) on the truck :

1. The truck should be emptied and cleaned before any installation. The truck should be parked on a level solid surface, a concrete floor if possible.
2. All lights, tags, steps, etc. that will interfere with the installation should be removed and/or relocated.
3. Position the lifter(s) on the sill of the truck per Figure A-1 and mounting height drawing and tack weld in place. See **Appendix A** for drawings. If using a mounting plate kit for bolt on applications, tack weld the mounting plate in place and attach the lifter to the mounting plate using the 1/2" studs.

#### NOTICE

Tack weld only at this time so that adjustments can be made if necessary.

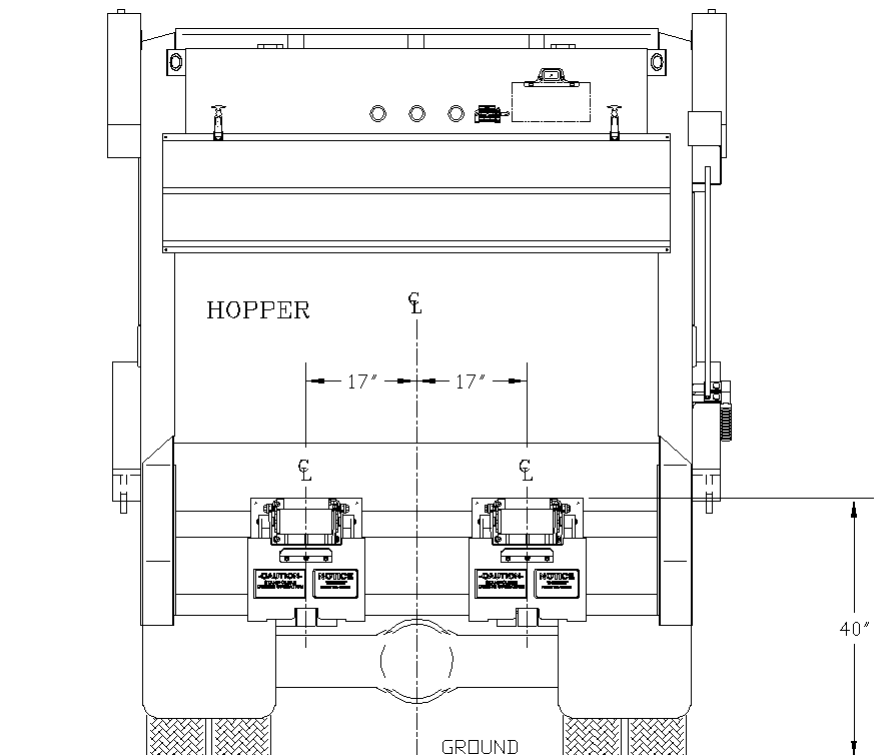

Figure A-1

# MBTL 180

## Installation Instructions

### B. Mounting hand valve(s) on the truck :

1. Choose and mark an acceptable location(s) on the side(s) of the truck to mount the hand valve assembly(s) ( Figure 2 ).
2. Remove the mounting bracket(s) from the hand valve assembly(s) and weld to the truck.
3. After the weld has cooled, paint the mounting bracket(s) to match the truck color.
4. After the paint has dried, reassemble the hand valve assembly(s) on the mounting bracket(s).

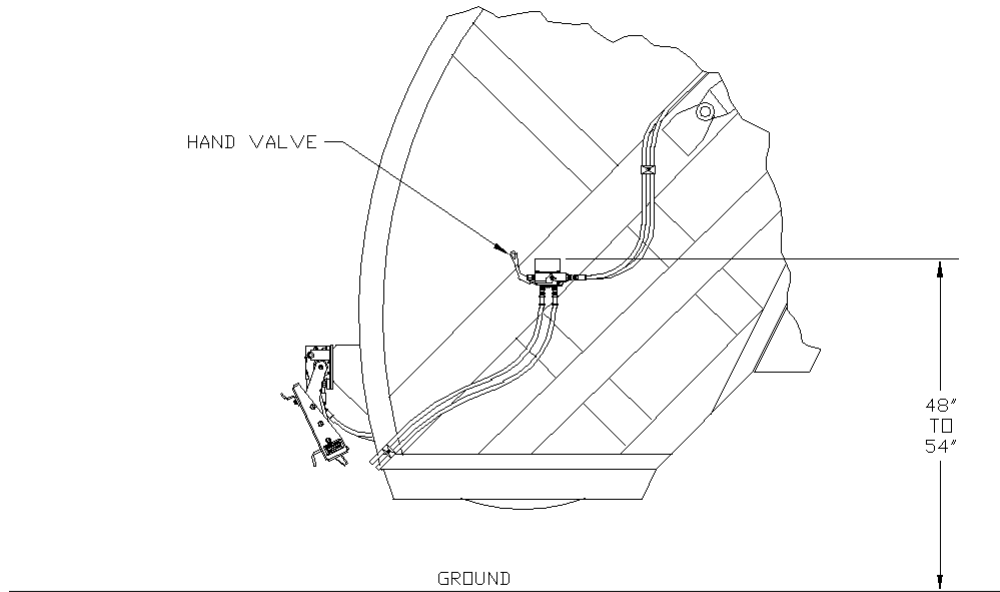

**Figure A-2**

### C. Mounting diverter valve on the truck :

1. Choose and mark an acceptable location to mount the diverter valve assembly. This location should be near the truck's main hydraulic pressure and tank lines on the same area of the truck where the lifter is mounted.
2. Weld diverter valve mounting bracket to the truck.
3. After the weld has cooled, paint the mounting bracket to match the truck color.
4. After the paint has dried, bolt the diverter valve to the mounting bracket using the 1/4" bolts, washers, and elastic lock nuts.

# MBTL 180

## Installation Instructions

### D. Making Hydraulic Connections :

Before attempting any hydraulic connections, turn the truck's engine off and release all hydraulic pressure from the system. Refer to the hydraulic layouts ( Figure A-3) and hydraulic schematics while performing the following steps. See **Appendix A** for drawings.

#### NOTICE

Always clean & lubricate fitting threads before installation.

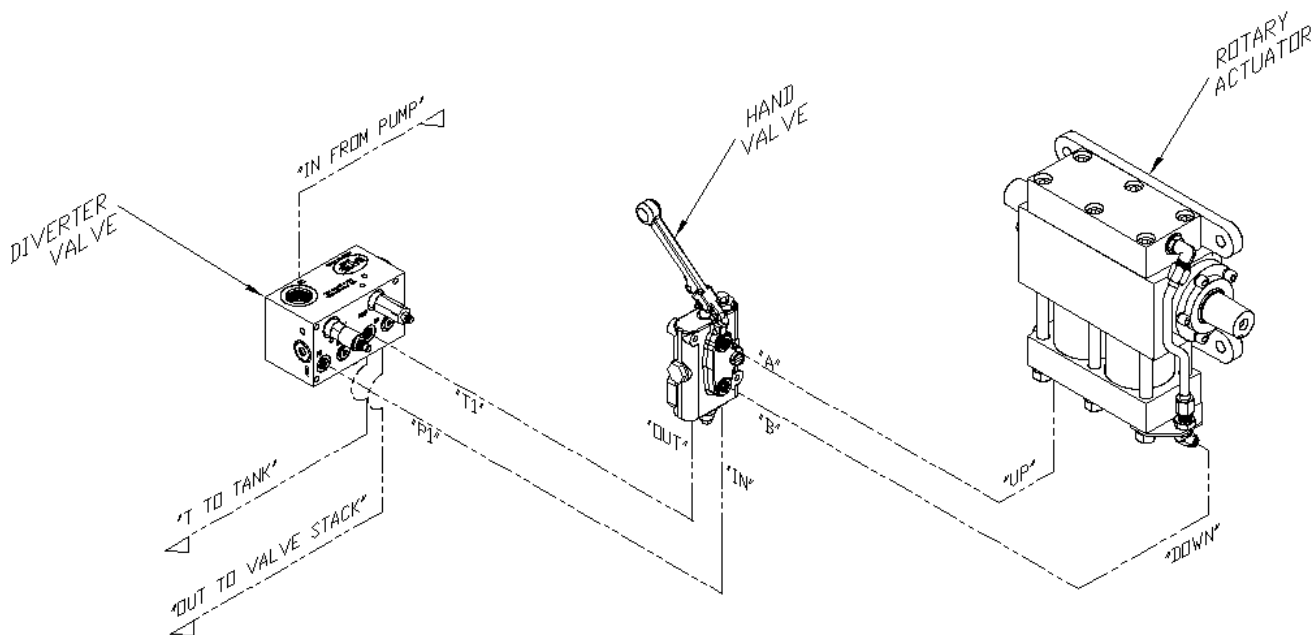

Single Lifter Installation

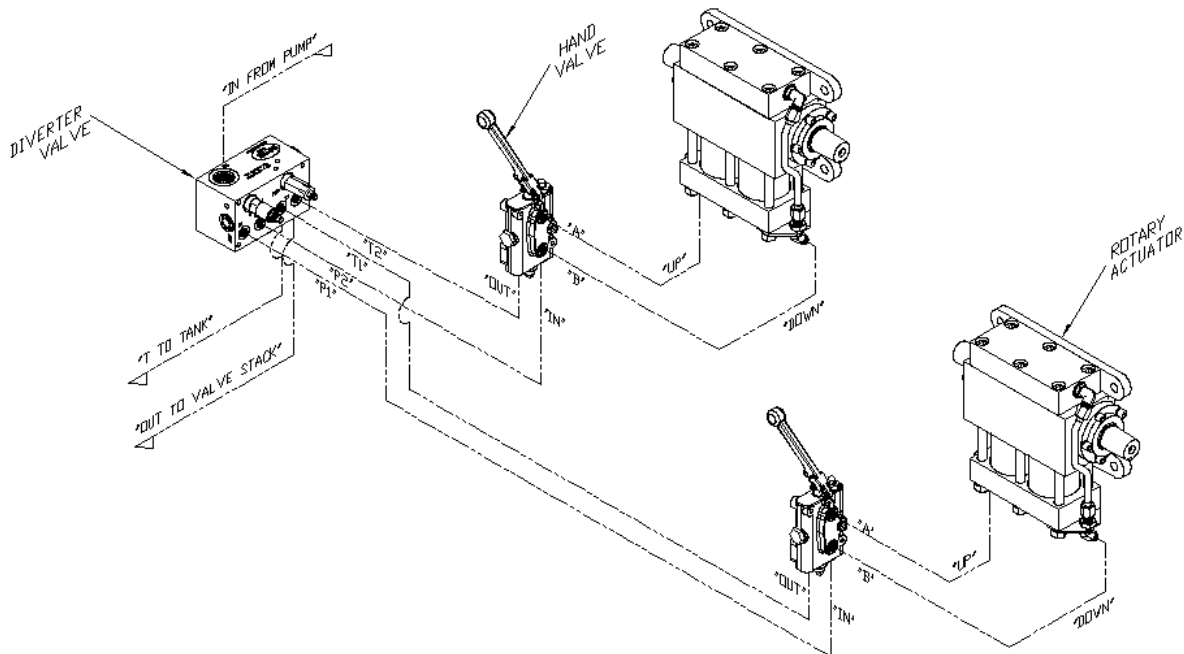

Dual Lifter Installation  
Figure A-3

# MBTL 180

## Installation Instructions

1. Cut or disconnect truck's main hydraulic pressure line and install the diverter valve in series using the "IN" and "OUT" ports.
2. Connect the "T" port on the diverter valve to the truck's hydraulic tank line with an appropriate size line to handle the full system flow.
3. Connect the "P1" port on the diverter valve to the "IN" port on the hand valve. **If installing dual lifters, connect the "P2" port on the diverter valve to the "IN" port on the other hand valve.**
4. Connect the "T1" port on the diverter valve to the "OUT" port on the hand valve. **If installing dual lifters, connect the "T2" port on the diverter valve to the "OUT" port on the other hand valve.**
5. Connect the "A" port on the hand valve(s) to the "UP" port of the rotary actuator(s).
6. Connect the "B" port of the hand valve(s) to the "DOWN" port of the rotary actuator(s).
7. Disassemble each hose clamp assembly and position weld plates where needed and weld in place.
8. After the weld has cooled, paint the weld plates to match the truck color.
9. After the paint has dried, reassemble the hose clamp assemblies around the hoses.

### E. Adjusting relief valve settings :

The diverter valve ( 1 ) ( Figure A-4 ) supplies the cart lifter hydraulic system with approximately 2 GPM of oil flow. This diverter valve is equipped with a full system relief valve ( 4 ) set at 2500 psi, to protect the truck's hydraulic system from any blockages that may occur down stream of the diverter valve. The diverter valve also includes a lifter circuit relief valve ( 3 ) set at 2300 psi, to prevent the diverter valve from shutting down if a blockage occurs in the lifter circuit. There is also a relief valve ( 5 ) set at 1800 psi in the hand valve ( 2 ) to protect the lifter from excessive pressure. These relief valves are preset from the factory to operate properly on most trucks with a system pressure between 2300 and 2500 psi without any adjustment. However, if any adjustment is necessary, follow these instructions.

### WARNING

Bayne equipment is rated for a maximum pressure of 3000 psi. Operation at pressures above 3000 psi may damage equipment and cause personal injury. In order to avoid injury and maintain manufacturer's warranty never operate above 3000 psi.

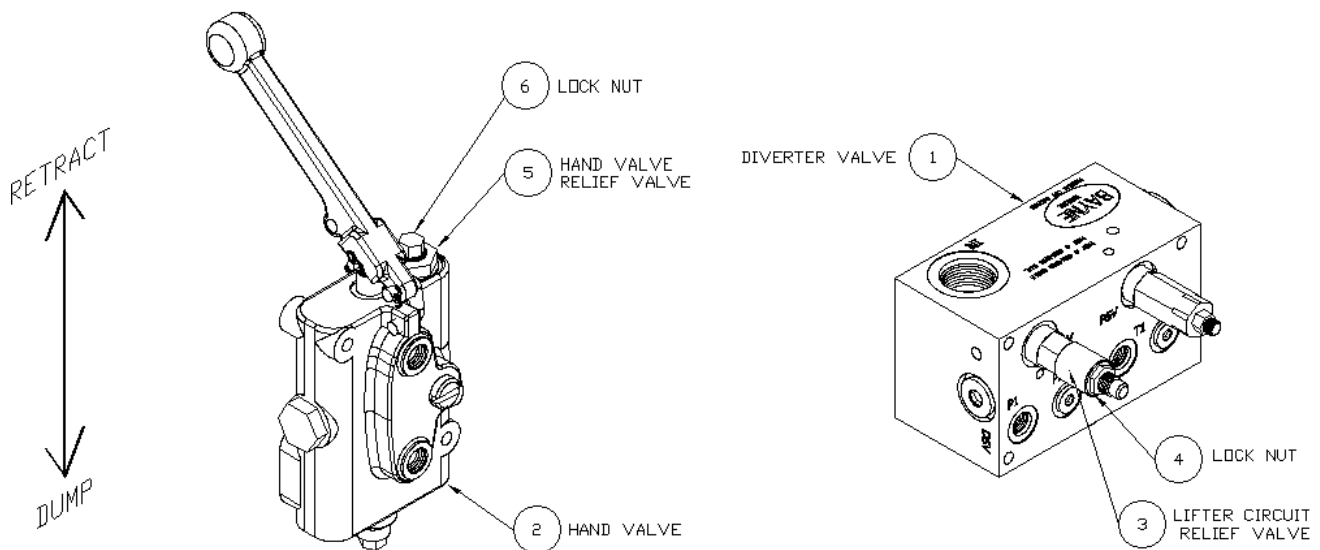

Figure A-4

# MBTL 180

## Installation Instructions

1. Determine the truck's system pressure setting.
2. Remove the cap nut(s) ( 8 ) ( Figure A-4 ) from the hand valve relief valve(s) ( 5 ) and turn the adjustment screw(s) clockwise until it bottoms out.
3. Loosen the lock nut ( 6 ) ( Figure A-4 ) on the lifter circuit relief valve ( 3 ) and turn the adjustment screw clockwise until it bottoms out.
4. Loosen the lock nut ( 7 ) ( Figure A-4 ) on the full system relief valve ( 4 ) and turn the adjustment screw counter-clockwise until it stops backing out.
5. Install a 3000 psi hydraulic pressure gauge with the necessary adapter in the "G" port of the diverter valve.
6. Start the truck's engine and engage the hydraulic system.
7. Operate the handle on the hand valve ( 2 ) ( Figure A-4 ) back and forth a few times to bleed all air from the lifter hydraulic system.
8. Setting the diverter valve full system relief valve :
  - a. Have an assistant hold the handle on the hand valve ( 2 ) ( Figure A-4 ) in the "retract" position. **If installing dual lifters hold the handle down on only one of the hand valves.**
  - b. Turn the pressure relief adjustment screw on the full system relief valve ( 4 ) clockwise until the pressure reading on the gauge is either 100 psi above truck system pressure, or if the pressure reaches a certain point and will not go any higher, set the adjustment screw 1/2 turn past that point.
  - c. Release the handle on the hand valve.
9. Turn the truck's engine off and release all hydraulic pressure from the system.
10. Remove the hydraulic pressure gauge from the "G" port of the diverter valve and reinstall the plug.
11. Install the 3000 psi hydraulic pressure gauge with the necessary adapter in the hydraulic line connected to the "IN" port of the hand valve as shown in Figure A-5. **If installing dual lifters, install the hydraulic gauge at either one of the hand valves.**

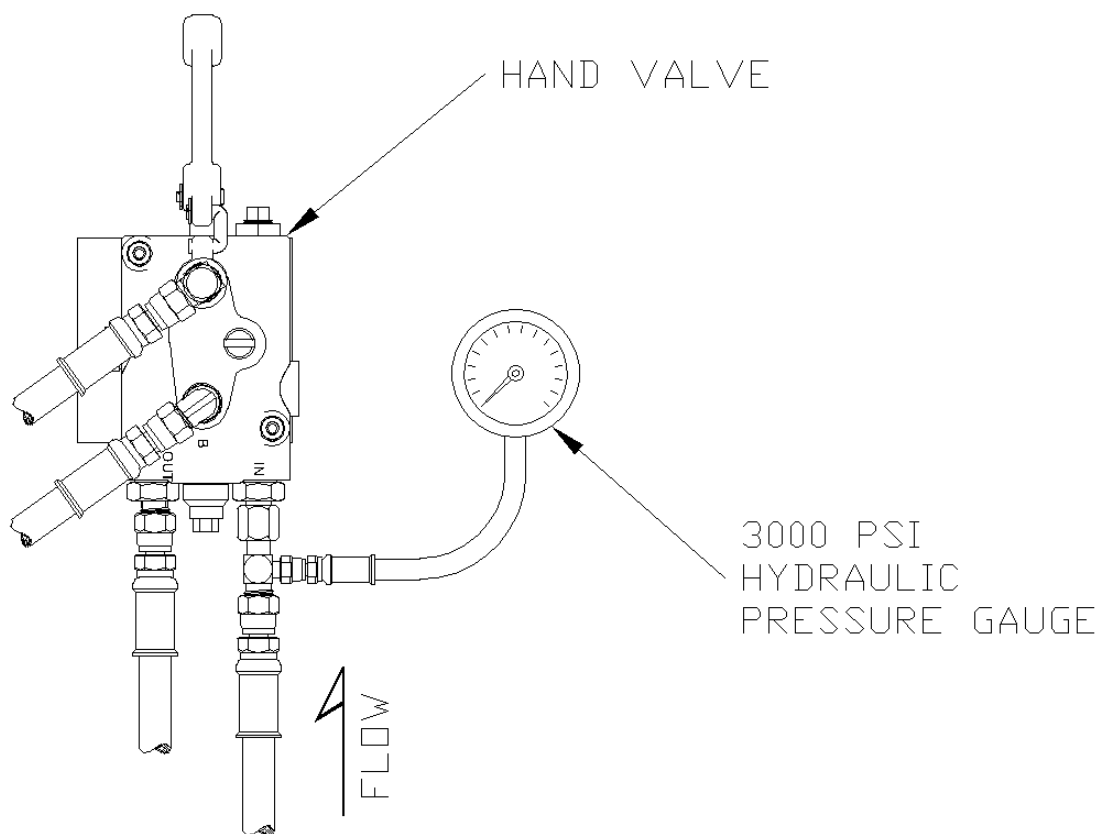

Figure A-5

# MBTL 180

## Installation Instructions

12. Start the truck's engine and engage the hydraulic system.
13. Setting the diverter valve lifter circuit relief valve :
  - a. Have an assistant hold the handle on the hand valve ( 2 ) ( Figure A-4 ) ( with pressure gauge installed at the "IN" port ) in the "retract" position to show pressure on the gauge.
  - b. Turn the pressure relief adjusting screw on the lifter circuit relief valve ( 3 ) counter-clockwise until the pressure reading on the gauge is either 100 psi less than the truck system pressure or 2300 psi, which ever is the lowest.
  - c. Release the handle on the hand valve.
14. Setting the hand valve relief valve(s) :
  - a. Hold the handle on the hand valve ( 2 ) ( Figure A-4 ) ( with pressure gauge installed at the "IN" port ) in the "retract" position to show pressure on the gauge.
  - b. Turn the pressure relief adjusting screw on the hand valve relief valve ( 5 ) counter-clockwise until the pressure reading on the gauge is either 200 psi less than truck system pressure or 1800 psi, which ever is the lowest.
  - c. Release the handle on the hand valve.
  - d. Turn the truck's engine off and release all hydraulic pressure from the system.
  - e. Remove the hydraulic pressure gauge from the hydraulic line connected to the "IN" port of the hand valve.
  - f. For dual lifters, install the hydraulic pressure gauge in the "IN" port of the other hand valve as shown in Figure A-5, start the truck's engine, engage the hydraulic system, and repeat step 14.
15. Reinstall the cap nut(s) ( 8 ) ( Figure A-4 ) on the hand valve relief valve(s) ( 5 ) to secure the correct pressure setting (s).
16. Tighten the lock nut ( 7 ) ( Figure A-4 ) on the full system relief valve ( 4 ) to secure the correct pressure setting.
17. Tighten the lock nut ( 6 ) ( Figure A-4 ) on the lifter circuit relief valve ( 3 ) to secure the correct pressure setting.
18. The hydraulic circuit pressures are now set for optimum performance.

### F. Final operation and mounting:

1. Start the truck's engine and engage the hydraulic system.
2. Place a cart on each lifter and operate to make sure there are no clearance problems and that the lifter engages the cart properly. Make any adjustments to the mounting position of the lifter(s) to ensure correct operation.
3. After locating an acceptable mounting position, complete the welding of the lifter(s) to the truck.

# MBTL 180

## Operation Instructions

### OPERATION INSTRUCTIONS

WI-0406-B

The **Bayne THINLINE®** Premium Lift System is a high quality durable cart lifter built to meet your industry's requirements. To insure the safety of all operators of this equipment, please read this manual carefully before operating the lifter. **FAILURE TO COMPLY WITH INSTRUCTIONS COULD RESULT IN PERSONAL INJURY AND/OR PROPERTY DAMAGE.**

The operating stages ( Figure B-1 ) in the cycle of the cart lifter are as follows:

1. **START** - The cart to be dumped is placed on the lifter.
2. **ACTUATOR DUMP** - The rotary actuator cycles to dump the contents of the cart into the box. During this cycle, the slider latch automatically extends to "lock" the cart to the lifter.
3. **ACTUATOR REVERSE** - The rotary actuator reverses its cycle returning the cart to the start position. The slider latch automatically retracts to "unlock" the cart from the lifter.

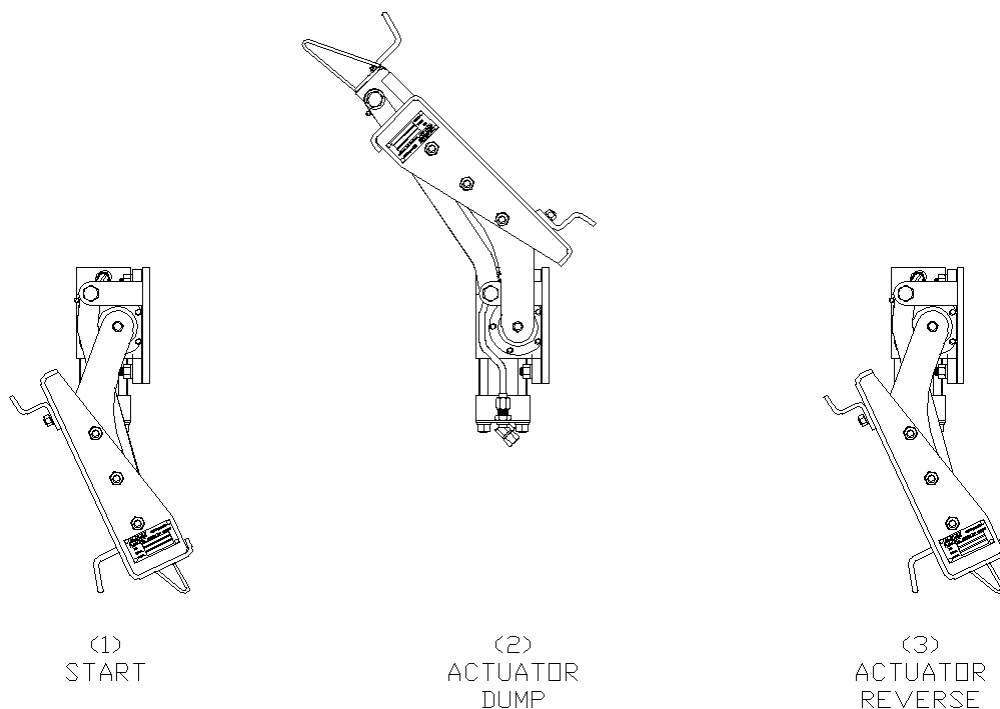

**Figure B-1**

### **WARNING**

Operating under the recommended cycle time on any lifter will void the manufacturer's warranty

The rotational motions of the cart lifter are controlled with the use of a hand valve. Moving the handle on the hand valve in one direction will cause the lifter to perform the actuator dump stage ( Figure B-1 ). Moving the handle in the opposite direction will cause the lifter to perform the actuator reverse stage.

### SAFETY ZONES

#### Stand Clear Zone

To prevent serious injury or death, operators and bystanders should remain outside the Stand Clear Zone ( Figure B-2 ) at all times during the operating cycle of the lifter. If at any point during the cycle persons enter this area, the operator must stop all motion of the lifter until the area is cleared.

#### Dump Zone

To prevent serious injury or death, operators and bystanders should remain outside the Dump Zone ( Figure B-2 ) at all times. If it becomes necessary to enter this area, all applicable OSHA lockout/tagout regulations must be followed.

#### Operator Area

To provide a clear, unobstructed view of both the Stand Clear Zone and Dump Zone, operators should remain within the Operator Area ( Figure B-2 ) at all times during the operating cycle of the lifter.

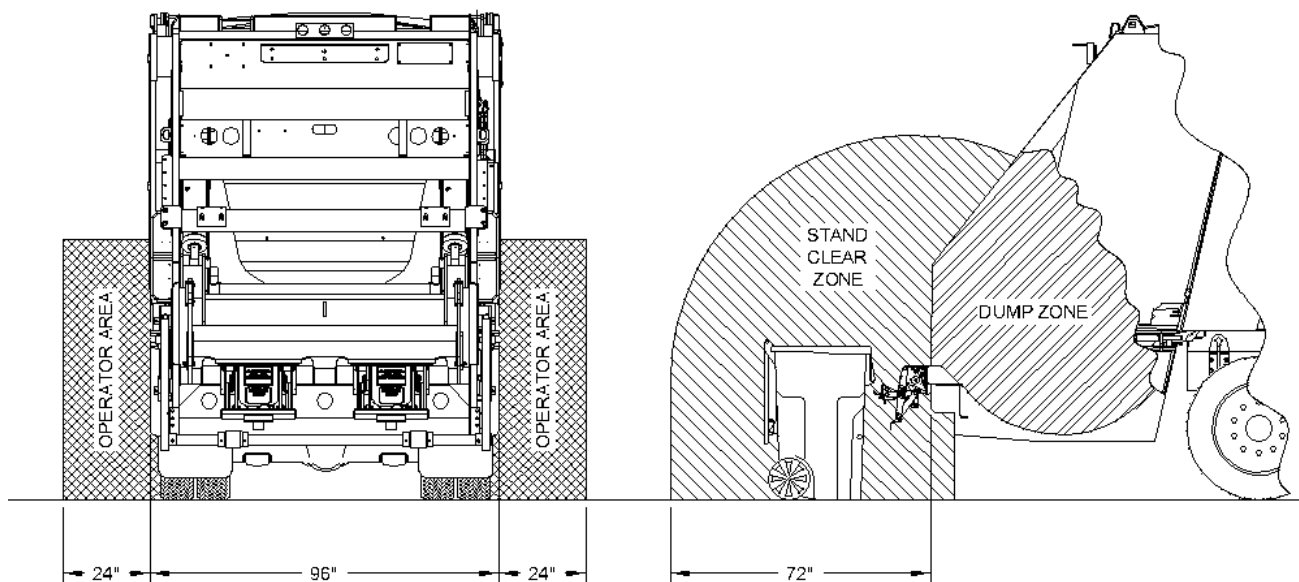

Figure B-2



# MBTL 180

## Diverter Valve Information

### OPERATION AND INSTALLATION INFORMATION

WI-0026

The Bayne diverter valve establishes priority flow to the lifter circuit "P1" and "P2" ports and bypasses oil to the "OUT" port, which typically supplies flow to the remainder of the truck's hydraulic circuit. This bypass occurs only after the lifter circuit is satisfied. The priority flow is controlled by the flow regulator cartridge (FR1) (and FR2 in dual applications) in combination with the differential pressure sensing valve (DPS). This allows the valve to maintain constant flow regardless of changes in load pressure or volume flow rate. Since both the lifter circuit and bypass flow can be utilized in the operation of the truck regardless of which pressure is greater, a single pump can be used to supply two circuits or operations.

The lifter circuit flow is regulated and maintained by the flow regulator cartridge (FR1) (and FR2 in dual applications). The differential pressure sensing valve (DPS), rated for 75 gpm of flow and 3000 psi of pressure, is operated by an internal spring and dampening orifice (OR) which establishes a pressure drop across the block sufficient to ensure the correct operation of the flow regulator (FR1). For a dual diverter valve, a second flow regulator cartridge (FR2) is installed in the "FR2" cavity and a shuttle valve (DSV) is installed in place of the SAE plug in the "DSV" cavity. Once the pressure drop is established, a precision metered flow is provided to the tipper circuit(s) with additional flow being bypassed to the "OUT" port.

The operation of the diverter valve does not require the use of a tank line to be run to the "T" port. However, the efficiency of the block will be significantly increased if a tank line is installed. The logic circuit of the block will manage the flow of oil returning from the tipper circuit to ensure optimum performance. This is primarily controlled with the sequence valve (PSV) which is factory set and should not be adjusted. All oil returning from the tipper circuit will normally be regenerated into the outgoing flow to ensure that the downstream functions are not slowed in any way. When the downstream backpressure rises to a predetermined pressure, the block will redirect the flow to the "T" port to increase the overall efficiency of the block and reduce the pressure drop through the block. If the "T" port is connected to a tank line, the oil will be dumped through the block at a lower pressure. This allows downstream functions to operate at the highest possible pressure when pressure is being required. If the "T" port is blocked, the oil will be redirected back into the outgoing flow through the check valve (CV).

A relief circuit for the tipper function is controlled by a relief valve (RV), which is preset to 2300 psi. This can be adjusted to limit pressure to the tipper(s). This relief valve is more efficient than the relief in the hand valve and will operate with less noise. It is recommended that it be adjusted to relieve before the hand valve relief. It may also be used to limit the weight the lifter can dump. This may be beneficial in avoiding damage to cans resulting from overloading. This should be the only adjustment that the block may require. Any other adjustments should only be made after close consultation with Bayne's Engineering Department to ensure proper operation.

# MBTL 180

## Diverter Valve Information

### Possible Problems

1. The most common cause of valve failure is dirty oil. If debris becomes lodged in the cartridge valves they will malfunction. Recommended filtration level is between 15 and 25 microns. Many systems filter the oil on the return side. This does not guarantee clean oil going into the system. It is important to ensure that the tank vent filtration element is properly maintained as well. Very small contaminants may not cause the valve to stop functioning, but can cause “stiction” in the cartridges between the body and the moving spool. This can cause improper operation. A slow moving tipper is most likely the result of contamination in the flow regulator cartridge. A pulsating noise may be the result of contamination in the differential pressure sensing valve causing it to stick. If any valve malfunctions, remove and thoroughly clean the valve, being extremely careful not to score or abrade the “o” ring seals or moving parts of the valve. Be sure that the spool moves freely in the valve body.
2. The flow regulator cartridges (FR1 and FR2) are designed to operate at a designated pressure of 80 psi. This means that in order for the valve to function properly, a minimum of 80 psi is required from the supply line through the “IN” port of the valve. This can present a problem on trucks with a dry valve pump system. Normally in the dry (off) mode of the pump, a flow of approximately 2 gpm at 20 psi is required to circulate through the open center system of the truck. This is for pump lubrication in the off mode. When the diverter valve is placed in the main pressure line of the truck, a blockage occurs because of the differential pressure sensing valve needing 80 psi to initially open and allow the flow regulators function. The path of the lubrication oil is therefore stopped because the valve does not open. When the oil is blocked, the pump will rotate and cavitate in the lubricating oil, causing heat to build up over an extended period of time, possibly leading to premature pump failure. To prevent this problem from occurring, a “bleed line” circuit needs be installed on the truck to allow passage of the lubricating oil back to tank.
3. On front load residential truck applications, several considerations need to be noted. The Bayne hand valve is an open center valve that allows for the lifter circuit to maintain flow through the hand valve and back to the diverter valve when the lifter is not being operated. If flow is not maintained through the hand valve, the oil will constantly be relieving over the lifter circuit relief valve (RV) in the diverter valve, which can cause an increase in operating temperature. Certain front load box designs allow for the hand valve to be located on the arms of the truck which keeps the hand valve in the lifter circuit at all times to maintain flow. Most problems occur with applications where the hand valve is located on the box itself. In this situation, when the operator disconnects the hydraulic lines to the box, a blocked condition occurs in the lifter circuit. To prevent this problem, the pump must be turned off prior to disconnecting the box hydraulic lines. Once the lines have been disconnected from the box, it is necessary to connect the two lines for the hand valve to each other to functionally complete the lifter circuit. It is recommended that male and female quick disconnects be used opposite each other on the truck to provide an uninterrupted circuit. Once the lines have been connected and the circuit continued, the pump could then be turned on to continue operations.

# MBTL 180

## Maintenance Instructions

### MAINTENANCE INSTRUCTIONS

WI-0140-A

#### NOTICE

---

The most common cause of hydraulic component failure is contamination of the hydraulic fluid ( water, chips, dirt, etc. )  
The **Bayne THINLINE®** Lift System comes clean from the factory. If removed, be sure the hoses, cylinder and fittings are clean before re-installing them on the unit.

---

Inspect your cart lifter on a weekly basis for loose bolts, fittings, oil leaks, etc. Tighten loose hardware as necessary and replace necessary seals to repair oil leaks.

In order to maintain warranty and for preventive maintenance, grease all points weekly with a good multi-purpose grease at points shown in the lubrication drawing. See **Appendix A** <sup>251</sup> for drawings.

# MBTL 180

## Actuator Assembly Instructions

### ACTUATOR ASSEMBLY INSTRUCTIONS

1100 Series Roller Bearing Actuator, Part Number 1120-1025 ( WI-1109-E)

Licensed under on or more of the following U.S. Patents: 4,773,812 1,327,765 5,308,211 5,333,984

#### NOTICE

READ INSTRUCTIONS COMPLETELY BEFORE STARTING ASSEMBLY.

Before starting the assembly of the Rotary Actuator, refer to the exploded parts drawing and parts list (Figure C-13 found at the end of these instructions) to familiarize yourself with the individual components. Prepare a clean surface, in an area free of blowing dust and contaminants in which to assemble the Rotary Actuator. Be sure that all parts are thoroughly clean and dry before starting assembly.

#### NOTICE

All torque values given apply to clean dry threads only. Follow these directions closely when repairing the Rotary Actuator.

1. Install the piston seal load ring (13) ( Figure C-1 ) in the small groove on the head of the actuator rack (2). Place the "square" piston seal (17) over the load ring (13) in the same small groove (a small "blunt" flathead screwdriver may be used, taking care not to scratch or damage the seal). Install the wear ring (18) in the large groove on the head of the rack. Using a ring compressor, firmly seat the rings on the rack before setting it aside, this will help to reverse the effects of any stretching of the rings that occurred during installation. Repeat this procedure for the other rack.

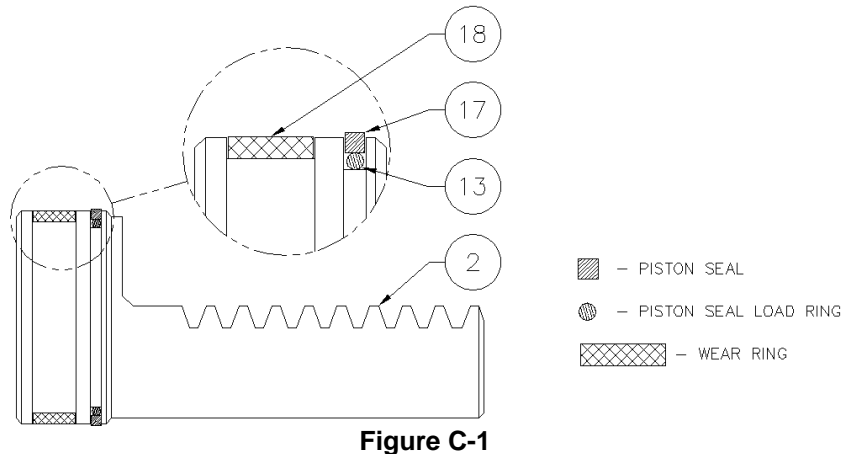

2. Install the tube seal (12) ( Figure C-2 ) and "square" tube seal backup (16) on each end of the actuator tubes (3) ( Figure C-13 ). Be sure that the "square" tube seal backup ring is toward the inside of the tubes at both ends as shown. Press all rings firmly into the grooves. Repeat this procedure for the other tube.

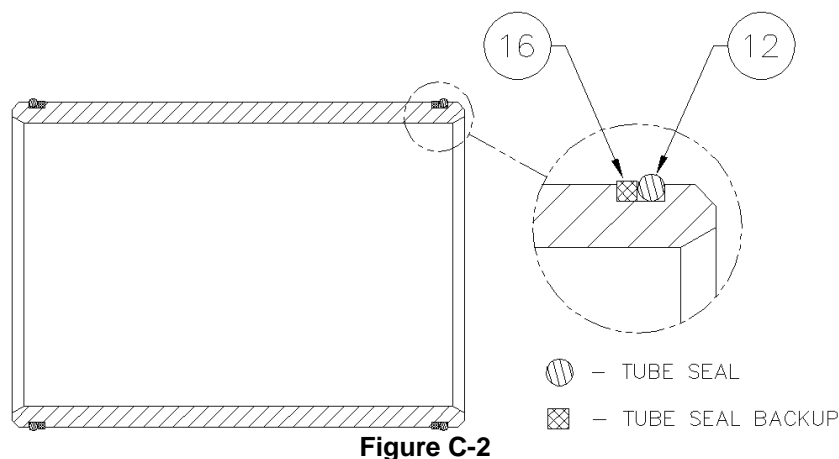

## Actuator Assembly Instructions

3. Thoroughly clean the pinion shaft (1) ( Figure C-3 ) and inner races (10) with a mild solvent and dry completely. Spray the inner race contact area (shown in Figure C-3 ) at each end of the pinion shaft and the inside diameter of the inner race thoroughly with LOCTITE 7649 N PRIMER. Apply LOCTITE RETAINING COMPOUND 609 around the pinion shaft at contact area and the inside diameter of the inner races. Slide the inner races (10) on the pinion shaft (radius end first as shown in Figure C-3) until the races seat against the gear teeth. After the races seat against the gear teeth, twist the races on the pinion 360° to spread the retaining compound evenly. Wipe off any excess retaining compound.

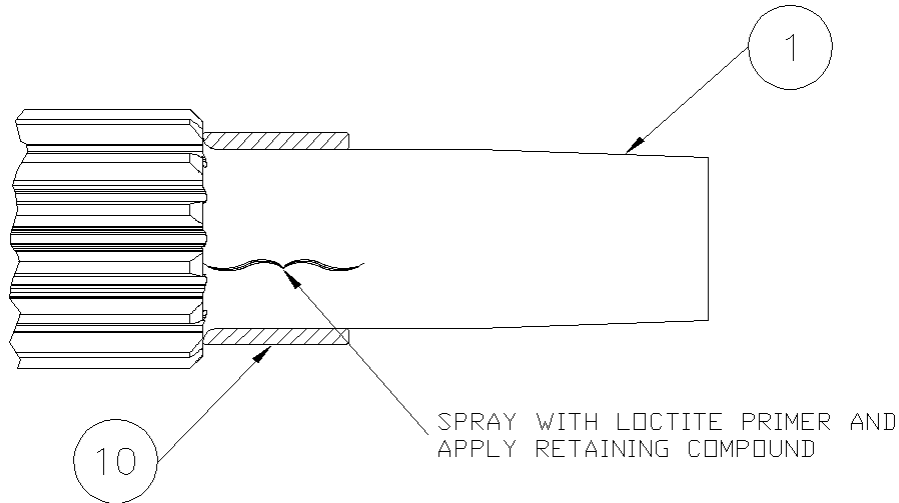

Figure C-3

4. Place the actuator body (7) ( Figure C-4 ) on the edge of the table, mounting flanges closest to the assembler with the counter-bores facing up. Insert the pinion shaft (1) through the bore on either side of the actuator body with the key ways facing back toward the mounting flanges and up away from the table with the center line of the key ways pointing toward the center of the tapped hole shown in Figure C-4. Center the pinion in the actuator body.

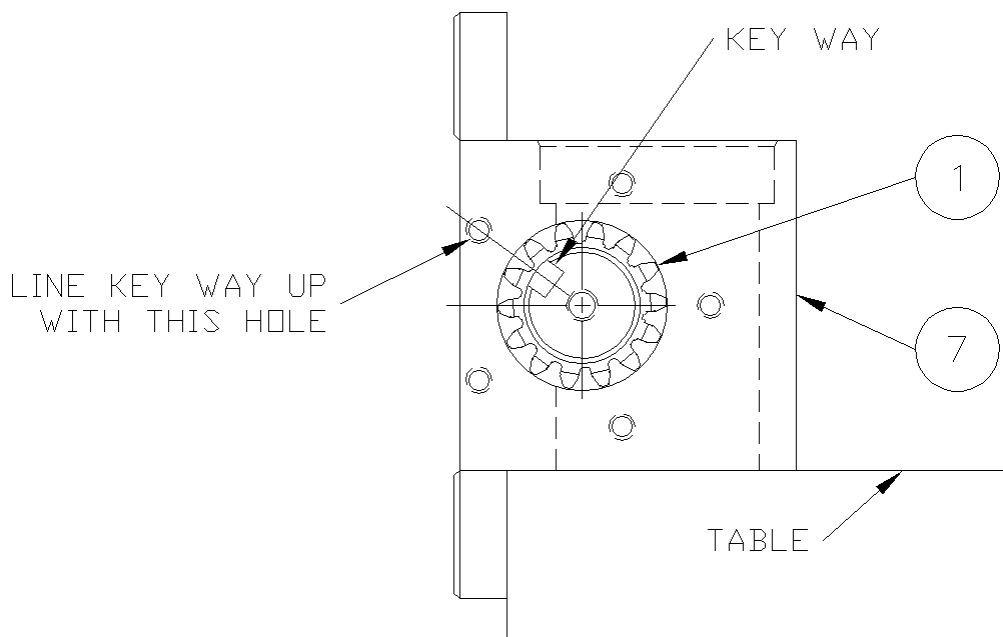

Figure C-4

## Actuator Assembly Instructions

5. Coat the head portion of the racks (2) ( Figure C-13 ) with STP Oil Treatment. Install the racks, head portion up with the teeth facing the flanges of the actuator body, into the dual set of bores in the body. Simultaneously slide the racks into the bores so that the racks mesh with the pinion in the same position. Rotate the pinion shaft to engage the racks into the pinion.

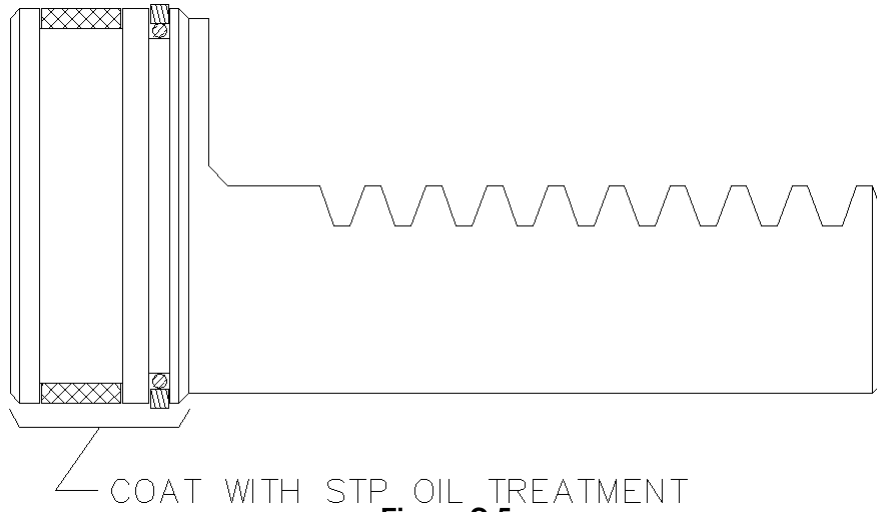

Figure C-5

6. Check the position of the racks in the pinion by making sure both racks seat against the actuator body at the same time and also when the racks are seated against the body, the key ways on the pinion shaft should be facing down toward the table and very slightly back toward the mounting flanges on the actuator body as shown in Figure C-6.

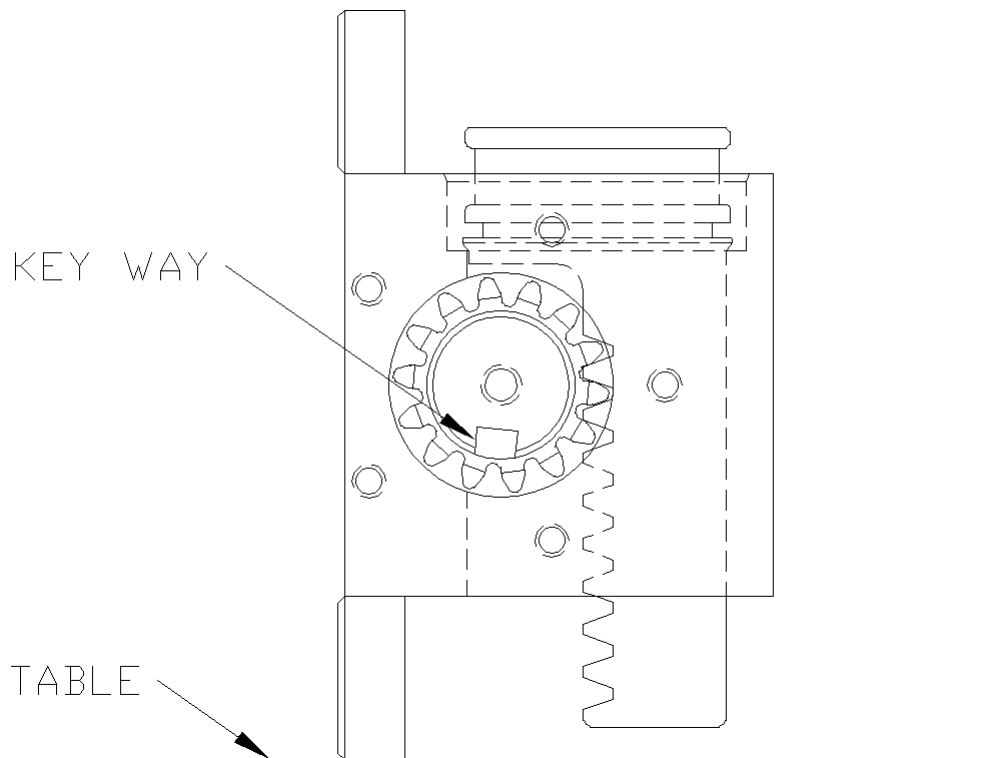

Figure C-6

## Actuator Assembly Instructions

7. Coat one end of the actuator tubes (3) ( Figure C-13 ) around the seal area with STP Oil Treatment as shown in Figure C-7. Using a rubber mallet, drive the coated end of the tube onto the exposed rack until the tube end seats in the actuator body, making sure that the seals remain in place as the tube enters the counter-bore. Repeat this procedure for the other side.

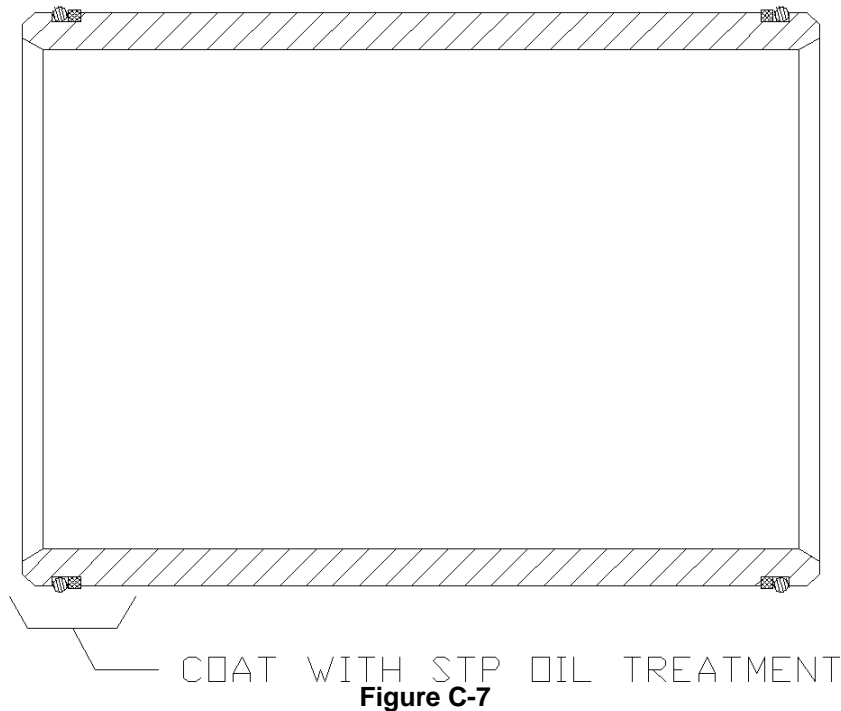
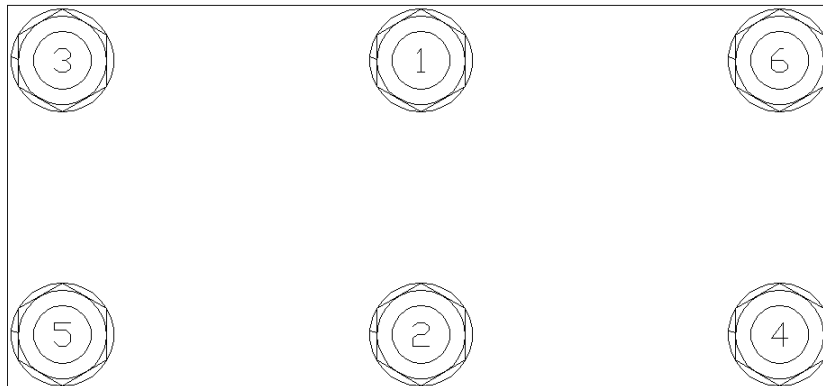

Figure C-7

8. Install the six tie rod studs (6) ( Figure C-13 ) by screwing the short threaded end into the actuator body. Hand tighten only at this time (the torque needed will be applied later in the procedure).
9. Place the tube cap (4) ( Figure C-13 ) on the table. Coat the sides of the two bores in the tube cap with STP Oil Treatment. Install the cap over the tubes and rod studs with the oil port positioned to the left as shown in Figure C-13. Using a rubber mallet, tap the tube cap over the tubes until the tubes seat in the cap, making sure that the seals remain in place.
10. Place the tube mounting bracket (30) ( Figure C-13 ) over the two end rod studs opposite the oil port in the tube cap as shown in Figure C-13.
11. Install the hex nuts (23) ( Figure C-13 ) and lock washers (24) on the tie rod studs. Torque the nuts to 50 ft-lb. in the sequence shown in Figure C-8.



TUBE CAP TORQUE SEQUENCE

Figure C-8

## Actuator Assembly Instructions

12. Place the rack cap (5) ( Figure C-13 ) bore side up on the table and coat the edge of each bore with STP Oil Treatment. Install the rack cap seals (14) ( Figure C-9 ) in the rack cap.

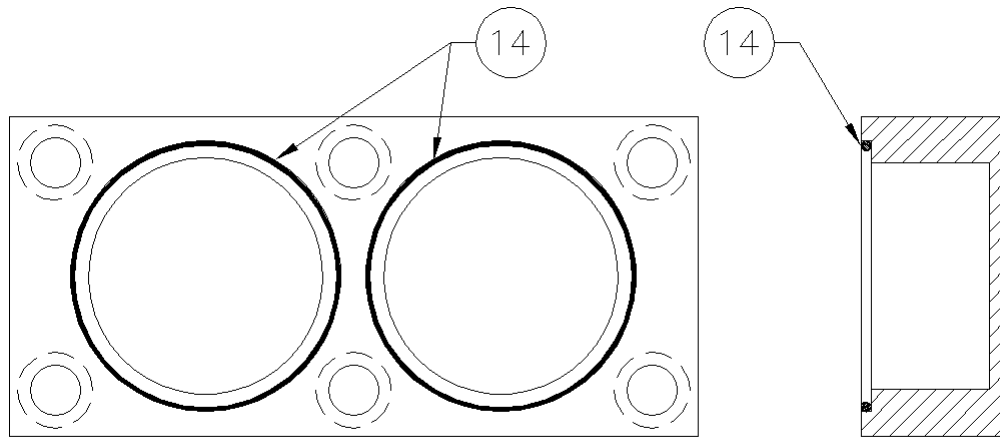

● – RACK CAP SEALS

**Figure C-9**

13. Reposition the actuator on the table mounting flanges down, and the lower tubes facing away from the assembler. Rotate the pinion shaft to allow 1" of the rack to protrude from the top of the actuator body. Install the rack cap with the oil port positioned to the left hand side of the actuator opposite the bottom oil port located in the tube cap as shown in Figure C-13. Attach the rack cap to the actuator body using the socket head bolts (22) ( Figure C-13 ) and lock washers (26). Torque the bolts to 90 ft-lb. in the sequence shown in Figure C-10.

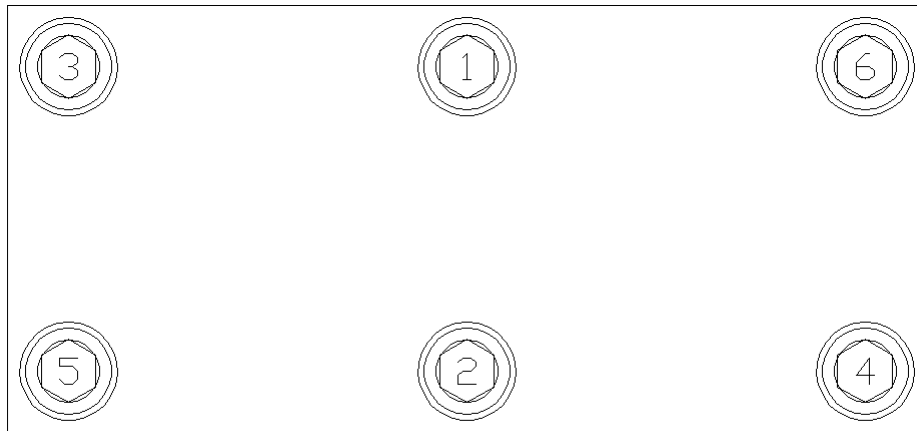

RACK CAP TORQUE SEQUENCE

**Figure C-10**

14. Reposition the actuator so that the pinion shaft can be rotated with no obstacles. Rotate the pinion shaft to ensure that the racks move freely. Also make sure that the key ways point perfectly straight "up" toward the rack cap and "down" toward the tube cap at each end of the 180° stroke. If the assembly does not perform all of these functions correctly, it must be disassembled, cleaned, and reassembled.
15. Re-center the actuator pinion in the actuator body by tapping on one end of the shaft with a rubber mallet. Install the roller bearing (9) ( Figure C-13 ), over the pinion shaft and inner race, and into the actuator body. Repeat this procedure for the other bearing.



## Actuator Assembly Instructions

16. Thoroughly clean the bearing caps (8) ( Figure C-11) with a mild solvent and lubricate all seal grooves with STP oil treatment. Place the bearing caps (8) on the table (mounting surface down) and install the wiper ring (19) in the outside groove using a rubber mallet or small press. **(Avoid using tools that may damage seals or scratch bearing cap or bearing surfaces.)** Turn the bearing cap (8) over. Collapse the pinion seal (20) and carefully work it into the groove. Use fingers to carefully press the seal completely into the groove as shown in Figure C-11. **Be careful not to score or scratch the sealing surface during the installation.** Install the bearing cap seal (15) and thrust washer (32) into their respective grooves on the bearing cap mounting surface as shown in Figure C-11.
17. Coat the bearing cap seal area and pinion seal area shown in Figure C-11 lightly with STP Oil Treatment.

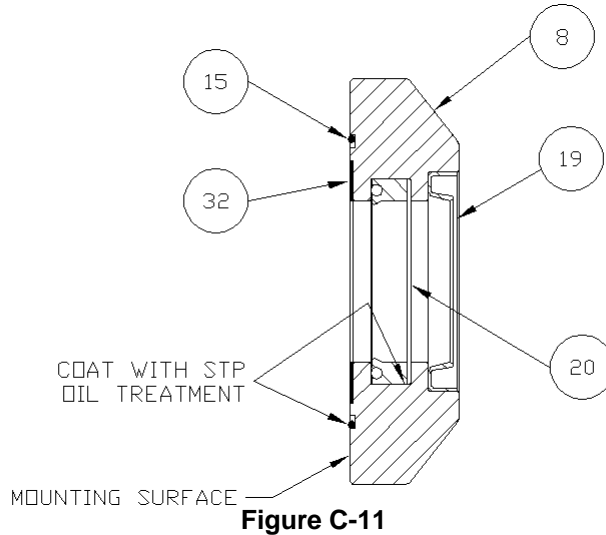

18. Wrap masking tape or electrical tape around the pinion to cover the edges at the keyway. Slide the bearing cap assembly over the pinion shaft with the bearing cap seal facing toward the actuator body and the flat surface of the flange shown in Figure C-12 facing toward the actuator mounting flanges. Press against the bearing cap until the shoulder seats against the actuator body, making sure that the seals remain in place. Install the bearing cap bolts (21) ( Figure C-13 ) and lock washers (25). Hand tighten only at this time. Repeat this procedure for other bearing cap.
19. After both bearing caps have been installed, torque all bearing cap bolts to 30 ft-lb. in the sequence shown in Figure C-12.

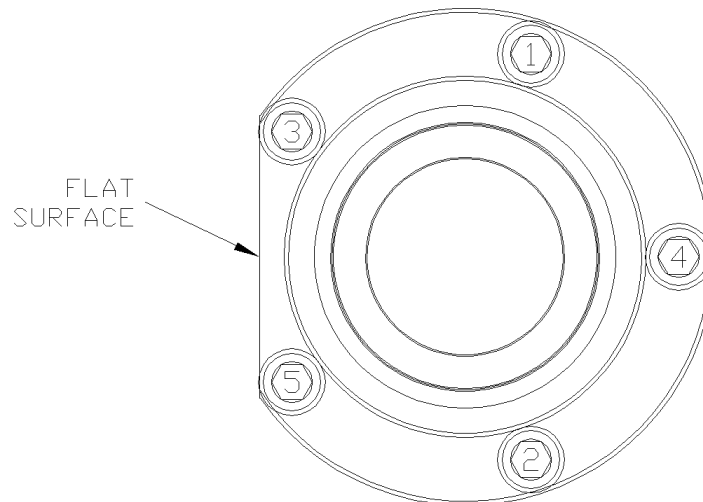

20. Install the 90° fitting (27) ( Figure C-13 ) into the oil port on the side of the rack cap (5). Hand tighten only at this time.

## Actuator Assembly Instructions

21. Install the 45° bulk-head fitting (31) ( Figure C-13 ) up through the hole in the tube mounting bracket (30) bolted to the tube cap as shown in Figure C-13. The 45° end must be pointing down away from the rack cap (5) and back toward the mounting flanges on the actuator body. Hand tighten only at this time.
22. Install the rack cap extension tube assembly (29) ( Figure C-13 ) between the 90° fitting in the rack cap and the 45° fitting in the tube mounting bracket as shown in Figure C-13. Tighten all connections.
23. Install the orifice plug (11) ( Figure C-13 ) into the oil port on the side of the tube cap (4), and install the 90° fitting (27) into the oil port over the orifice plug as shown in Figure C-13. Turn the fitting so that it points down away from the rack cap (5) and back toward the mounting flanges on the actuator body and tighten.
24. Install the cap nuts (28) ( Figure C-13 ) onto the open fittings to prevent contamination of the unit until the hoses are installed.
25. Install the actuator cover plate (33) ( Figure C-13 ) onto the rack cap (5) using the cover plate bolts (34). Be sure to use LOCTITE THREADLOCKER 242 on the cover plate bolts.

# MBTL 180

## Actuator Assembly Instructions

### ACTUATOR ASSEMBLY

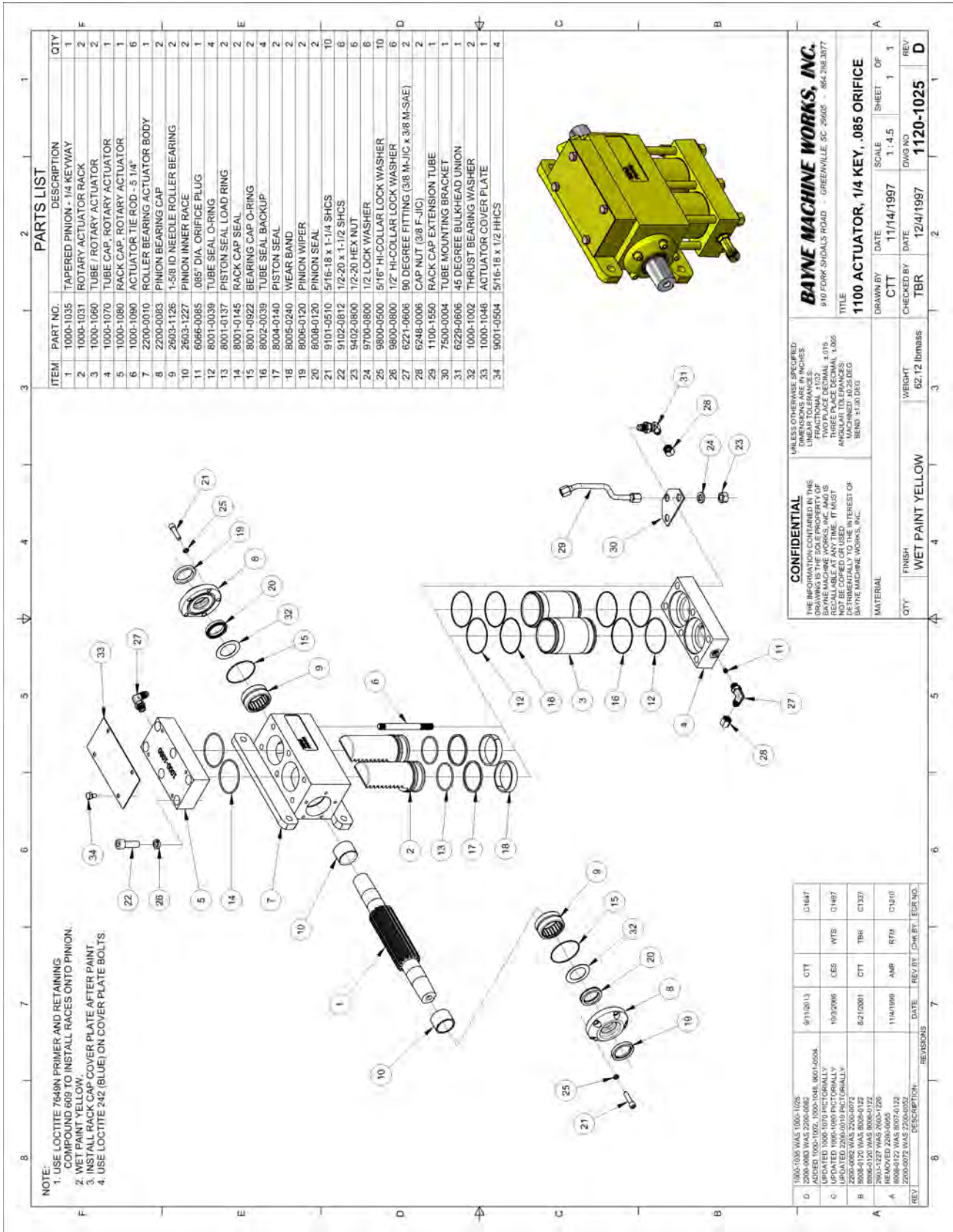

Figure C-13

# MBTL 180

## Troubleshooting Chart

<b>TROUBLESHOOTING CHART</b>		
<b>SYMPTOM</b>	<b>POSSIBLE CAUSES</b>	<b>CORRECTIVE ACTION</b>
<b>Lifter operation very erratic.</b>	1. Air trapped in system.	1. Bleed all air from lifter hydraulic system.
	2. Low oil level.	2. Add oil to system.
<b>Cart lifter will not pick up carts.</b>	1. Cart overweight.	1. Reduce loaded weight of cart.
	2. Lifter system hydraulic pressure too low.	2. Check and adjust pressure relief on hand valve and lifter circuit relief in diverter valve.
	3. Truck system hydraulic pressure too low.	3. Check and adjust pressure on truck system relief and full system relief in diverter valve.
	4. Faulty hand valve.	4. Replace hand valve.
<b>Lifter operates over recommended cycle time.</b>	1. Engine idle too low.	1. Adjust engine idle.
	2. Faulty hand valve.	2. Replace hand valve.
	3. Faulty truck hydraulic pump.	3. Consult truck maintenance manual.
	4. Trash in diverter valve.	4. Remove orifice from diverter valve body and clean thoroughly.
	5. Orifice in diverter valve is too small.	5. Remove orifice from diverter valve body and increase diameter.
<b>Lifter operates under recommended cycle time.</b>	1. Engine idle too high.	1. Adjust engine idle.
	2. Orifice in diverter valve is too large.	2. Remove orifice from diverter valve body and replace with a smaller diameter.
<b>Hydraulic components down stream of diverter valve not operating or operating extremely slow.</b>	1. Truck system hydraulic pressure too low.	1. Check and adjust pressure on truck system relief and full system relief in diverter valve.
	2. Faulty full system relief valve cartridge in diverter valve.	2. Replace full system relief valve cartridge in diverter valve.
	3. Faulty truck system relief valve.	3. Consult truck maintenance manual.
	4. System flow is being restricted.	4. Ensure there is proper flow throughout the hydraulic system. Remove any restrictions.
	5. Trash in flow regulator cartridge.	5. Remove flow regulator cartridge from diverter valve body and clean thoroughly.
<b>Diverter valve leaking oil around cartridges.</b>	1. Worn or damaged seals on cartridge valves.	1. Install diverter valve seal kit.
<b>Hand valve lever sticks in up or down position.</b>	1. Worn or broken spring center device.	1. Install spring center kit.
	2. Trash in or around hand valve shift spool.	2. Disassemble and clean spool and housing.
	3. Pressure ( IN ) and tank ( OUT ) ports are hooked up backwards.	3. Make sure all hoses are plumbed according to the hydraulic schematic.
<b>Hand valve leaking oil around shift spool.</b>	1. Worn or damaged seals.	1. Install hand valve seal kit.
	2. Worn spool.	2. Replace hand valve.
<b>Slider latch connectors frequently breaking or bending.</b>	1. Lift bars on cart bent or spread apart.	1. Replace cart or install new bars.
	2. Broken spring on slider latch hook.	2. Replace spring on slider latch hook.
	3. Lower hinged hook not operating freely.	3. Clean and grease hook area.

# MBTL 180

## Troubleshooting Chart

<b>TROUBLESHOOTING CHART</b>		
<b>SYMPTOM</b>	<b>POSSIBLE CAUSES</b>	<b>CORRECTIVE ACTION</b>
<b>Lifter loses bar lift carts when dumping.</b>	1. Lift bars on cart bent or spread apart.	1. Replace cart or install new bars.
	2. Broken spring on slider latch hook.	2. Replace spring on slider latch hook.
	3. Lower hinged hook not operating freely.	3. Clean and grease hook area.

# **APPENDIX A**

## **ASSEMBLY DRAWINGS AND PART NUMBERS**

# MBTL 180

## Appendix A - Assembly Drawings and Part Numbers

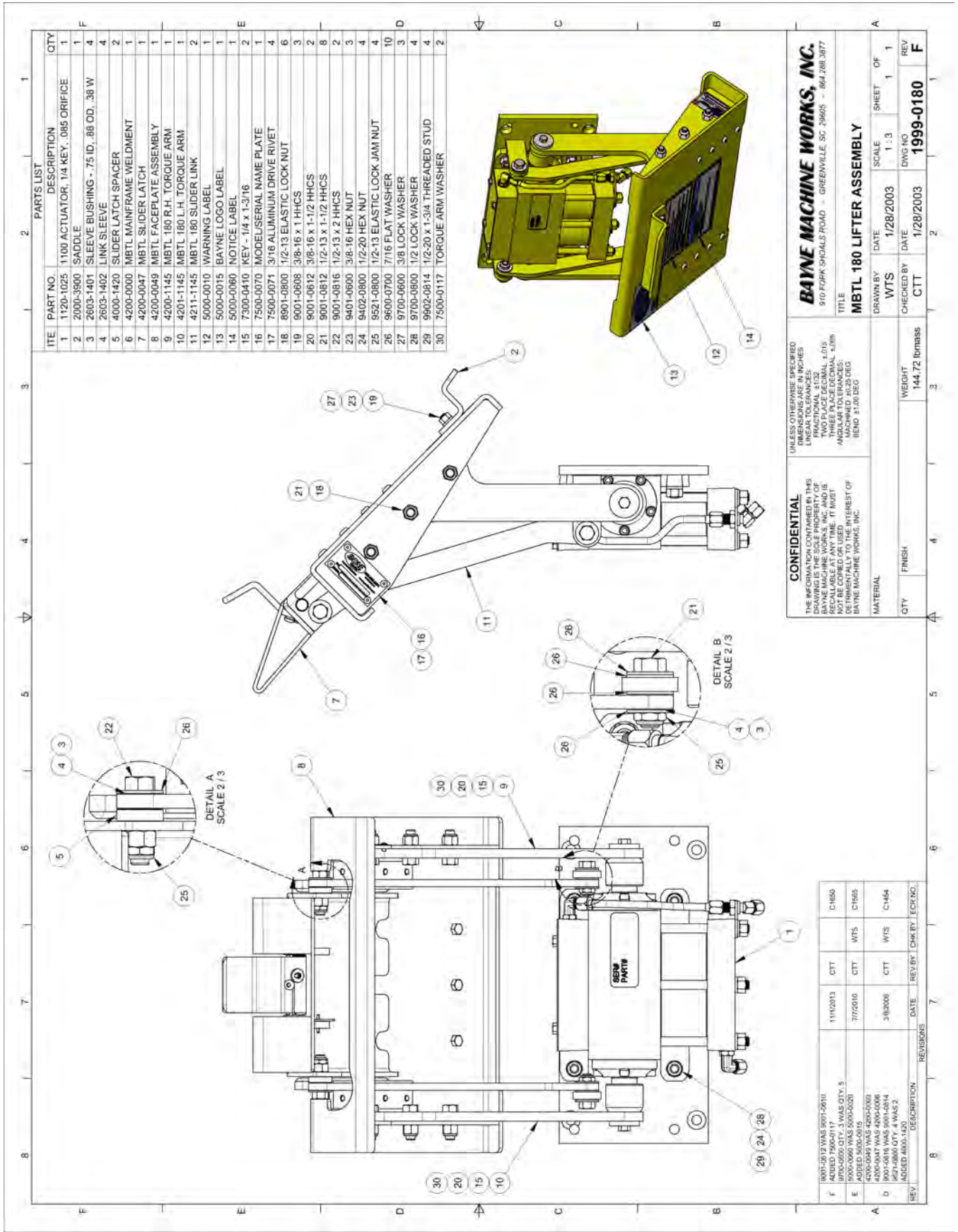

**CONFIDENTIAL**  
 THE INFORMATION CONTAINED HEREIN IS THE SOLE PROPERTY OF BAYNE MACHINE WORKS, INC. AND IS NOT TO BE REPRODUCED OR TRANSMITTED IN ANY FORM OR BY ANY MEANS, ELECTRONIC OR MECHANICAL, INCLUDING PHOTOCOPYING, RECORDING, OR BY ANY INFORMATION STORAGE AND RETRIEVAL SYSTEM. ANY UNAUTHORIZED USE OF THIS INFORMATION IS STRICTLY PROHIBITED AND WILL BE DEEMED TO BE TO THE INTEREST OF BAYNE MACHINE WORKS, INC.

UNLESS OTHERWISE SPECIFIED DIMENSIONS ARE IN INCHES  
 DIMENSIONS IN PARENTHESES ARE FRACTIONAL 1/32  
 TWO PLACE DECIMAL 1/16  
 THREE PLACE DECIMAL 1/32  
 MACHINED TO CLOSEST TOLERANCE  
 MACHINED TO CLOSEST TOLERANCE  
 BEND ±1.00 DEG

**CONFIDENTIAL**  
 THE INFORMATION CONTAINED HEREIN IS THE SOLE PROPERTY OF BAYNE MACHINE WORKS, INC. AND IS NOT TO BE REPRODUCED OR TRANSMITTED IN ANY FORM OR BY ANY MEANS, ELECTRONIC OR MECHANICAL, INCLUDING PHOTOCOPYING, RECORDING, OR BY ANY INFORMATION STORAGE AND RETRIEVAL SYSTEM. ANY UNAUTHORIZED USE OF THIS INFORMATION IS STRICTLY PROHIBITED AND WILL BE DEEMED TO BE TO THE INTEREST OF BAYNE MACHINE WORKS, INC.

REV	DESCRIPTION	DATE	REV BY	CHK BY	TECH NO.
F	ADDED 7500-0117 WAS QTY 5	11/15/2013	CTT	WTS	C1650
E	ADDED 5000-0015	7/7/2010	CTT	WTS	C1655
D	ADDED 5000-0015	3/8/2006	CTT	WTS	C1454
C	ADDED 4000-1420				

**BAYNE MACHINE WORKS, INC.**  
 910 FORK SHOALS ROAD - GREENVILLE, SC 29605 - 864.268.3877

**MBTL 180 LIFTER ASSEMBLY**

DRAWN BY	WTS	DATE	1/28/2003	SCALE	1:3	SHEET	1	OF	1
CHECKED BY	CTT	DATE	1/28/2003	DWG NO	1999-0180	REV	F		

**CONFIDENTIAL**  
 THE INFORMATION CONTAINED HEREIN IS THE SOLE PROPERTY OF BAYNE MACHINE WORKS, INC. AND IS NOT TO BE REPRODUCED OR TRANSMITTED IN ANY FORM OR BY ANY MEANS, ELECTRONIC OR MECHANICAL, INCLUDING PHOTOCOPYING, RECORDING, OR BY ANY INFORMATION STORAGE AND RETRIEVAL SYSTEM. ANY UNAUTHORIZED USE OF THIS INFORMATION IS STRICTLY PROHIBITED AND WILL BE DEEMED TO BE TO THE INTEREST OF BAYNE MACHINE WORKS, INC.

REV	DESCRIPTION	DATE	REV BY	CHK BY	TECH NO.
F	ADDED 7500-0117 WAS QTY 5	11/15/2013	CTT	WTS	C1650
E	ADDED 5000-0015	7/7/2010	CTT	WTS	C1655
D	ADDED 5000-0015	3/8/2006	CTT	WTS	C1454
C	ADDED 4000-1420				



# MBTL 180

## Appendix A - Assembly Drawings and Part Numbers

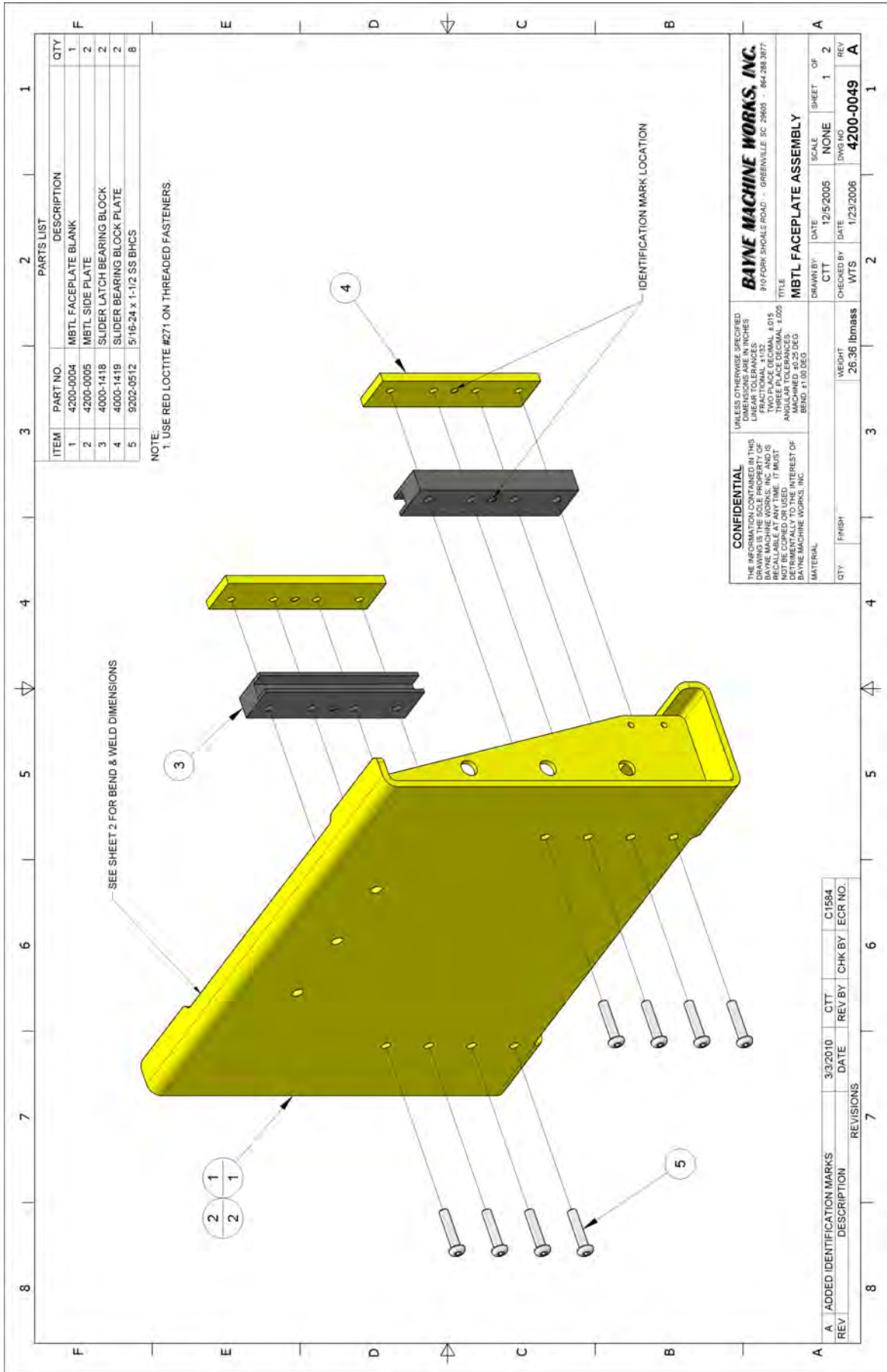



# MBTL 180

## Appendix A - Assembly Drawings and Part Numbers

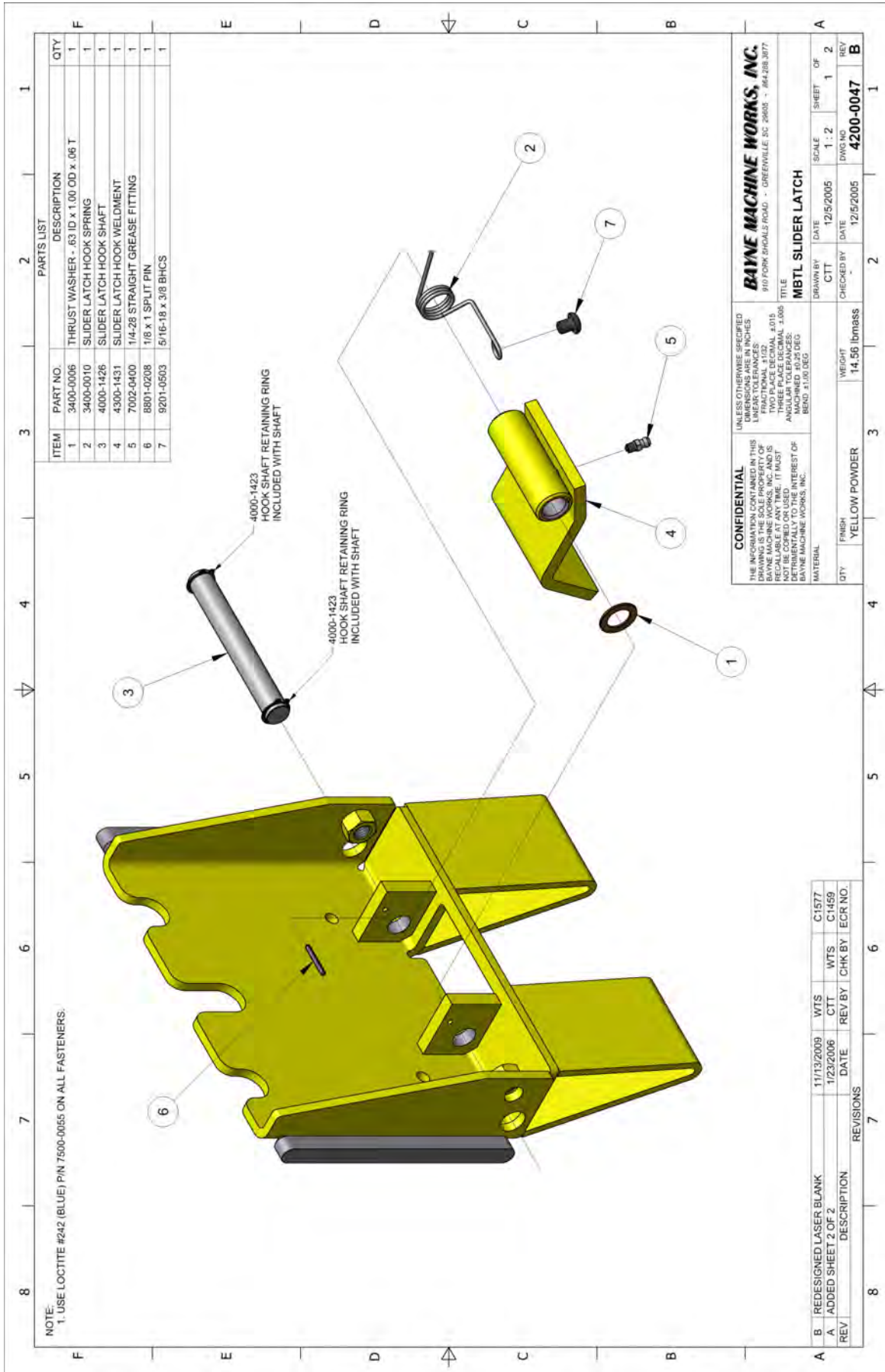

# MBTL 180

## Appendix A - Assembly Drawings and Part Numbers

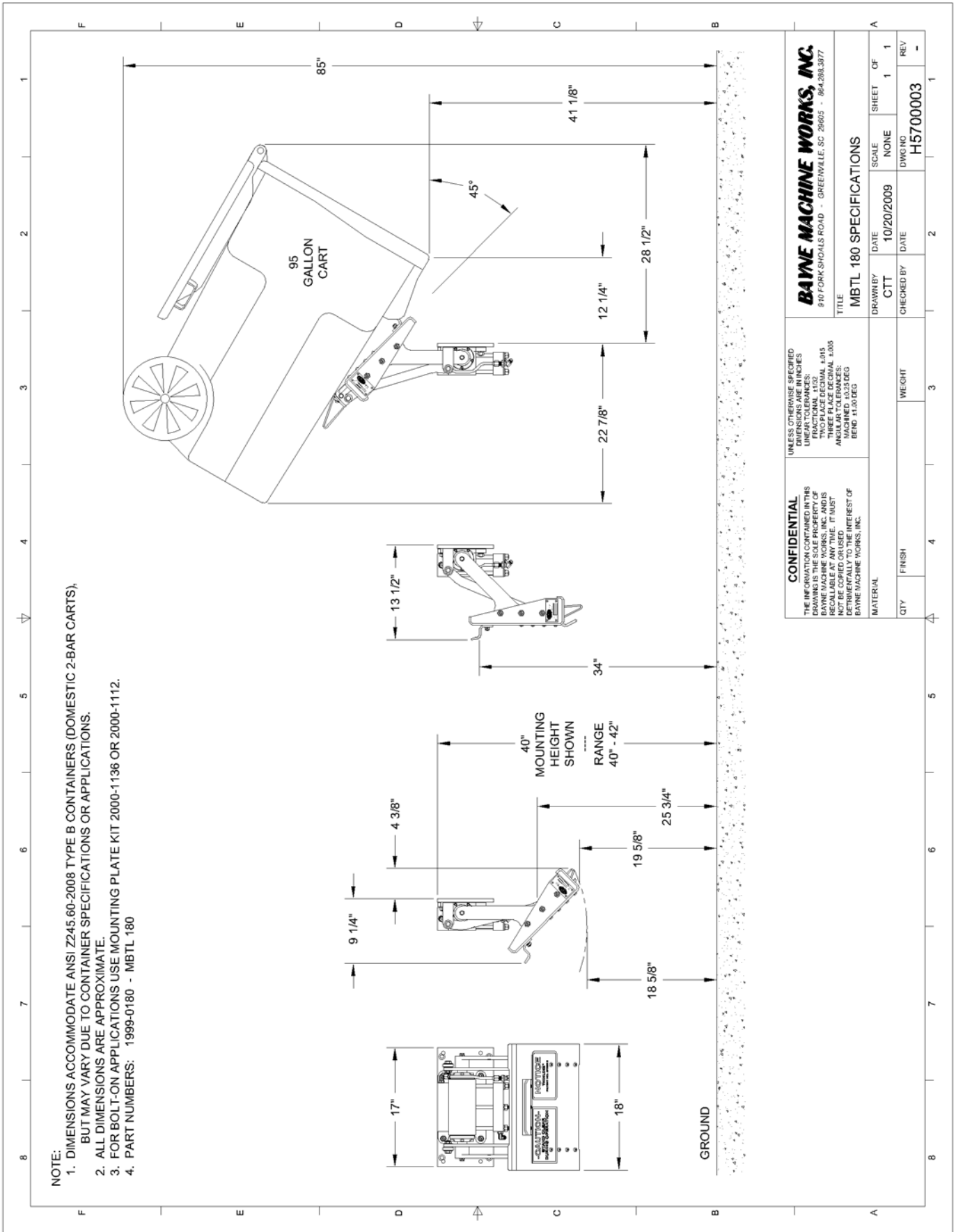

- NOTE:**
1. DIMENSIONS ACCOMMODATE ANSI Z245.60-2008 TYPE B CONTAINERS (DOMESTIC 2-BAR CARTS), BUT MAY VARY DUE TO CONTAINER SPECIFICATIONS OR APPLICATIONS.
  2. ALL DIMENSIONS ARE APPROXIMATE.
  3. FOR BOLT-ON APPLICATIONS USE MOUNTING PLATE KIT 2000-1136 OR 2000-1112.
  4. PART NUMBERS: 1999-0180 - MBTL 180

<p><b>CONFIDENTIAL</b> THE INFORMATION CONTAINED IN THIS DRAWING IS THE SOLE PROPERTY OF BAYNE MACHINE WORKS, INC. IT IS NOT TO BE REPRODUCED OR TRANSMITTED IN ANY FORM OR BY ANY MEANS, ELECTRONIC OR MECHANICAL, INCLUDING PHOTOCOPYING, RECORDING, OR BY ANY INFORMATION STORAGE AND RETRIEVAL SYSTEM. WITHOUT THE WRITTEN PERMISSION OF BAYNE MACHINE WORKS, INC. THIS DRAWING IS NOT BE COPIED OR USED IN ANY MANNER THAT IS DETRIMENTAL TO THE INTEREST OF BAYNE MACHINE WORKS, INC.</p>		<p>UNLESS OTHERWISE SPECIFIED DIMENSIONS ARE IN INCHES DIMENSIONS TO CENTER UNLESS NOTED OTHERWISE TYPICAL DECIMAL .015 THREE PLACE DECIMAL .005 ANGULAR TOLERANCES: HOLE POSITION ±.010 DEG BEND ±1.00 DEG</p>	
<p><b>BAYNE MACHINE WORKS, INC.</b> 810 FORK SHOALS ROAD - GREENVILLE, SC 29605 - 864.298.3977</p>			
<p>TITLE MBTL 180 SPECIFICATIONS</p>		<p>SCALE NONE</p>	<p>SHEET OF 1 1</p>
<p>DRAWN BY CTT</p>	<p>DATE 10/20/2009</p>	<p>CHECKED BY DATE</p>	<p>DWG NO H5700003</p>
<p>QTY</p>	<p>FINISH</p>	<p>WEIGHT</p>	<p>REV -</p>

# MBTL 180

## Appendix A - Assembly Drawings and Part Numbers

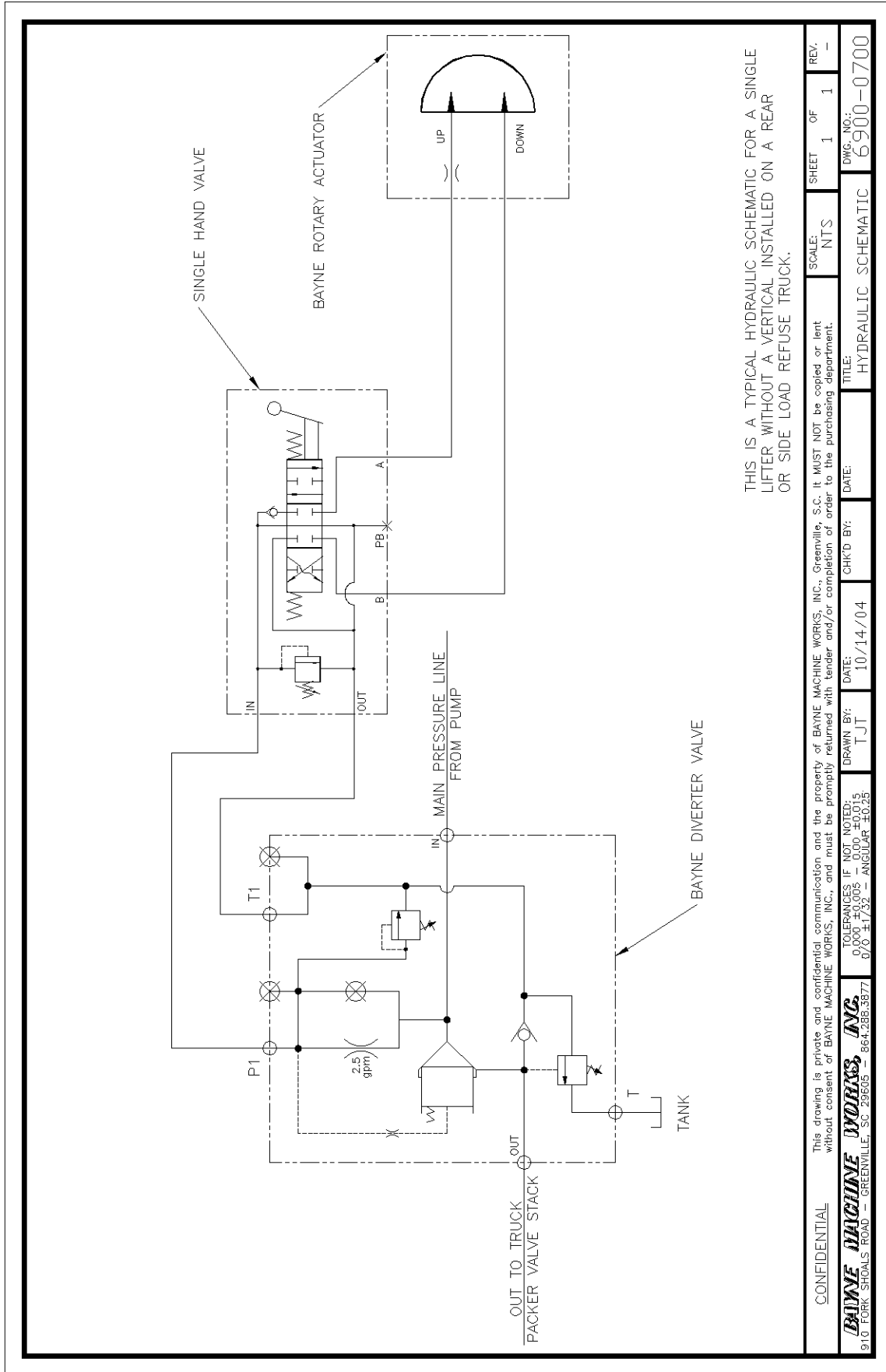

CONFIDENTIAL		This drawing is private and confidential communication and the property of BAYNE MACHINE WORKS, INC., Greenville, S.C. It MUST NOT be copied or lent without consent of BAYNE MACHINE WORKS, INC., and must be promptly returned with tender and/or completion of order to the purchasing department.		SCALE:	SHEET	OF	REV.
BAYNE MACHINE WORKS, INC.		TOLERANCES IF NOT NOTED: 0.000 ±0.005 - 0.00 ±0.015 0.70 ±1.732 - ANGULAR ±0.25		NTS	1	1	-
810 FORK SHOALS ROAD - GREENVILLE, SC 29605 - 864.286.3877		DRAWN BY:		DATE:		TITLE:	
		TJT		10/14/04		HYDRAULIC SCHEMATIC	
		CHK'D BY:		DWG. NO.:		6900-0700	

# MBTL 180

## Appendix A - Assembly Drawings and Part Numbers

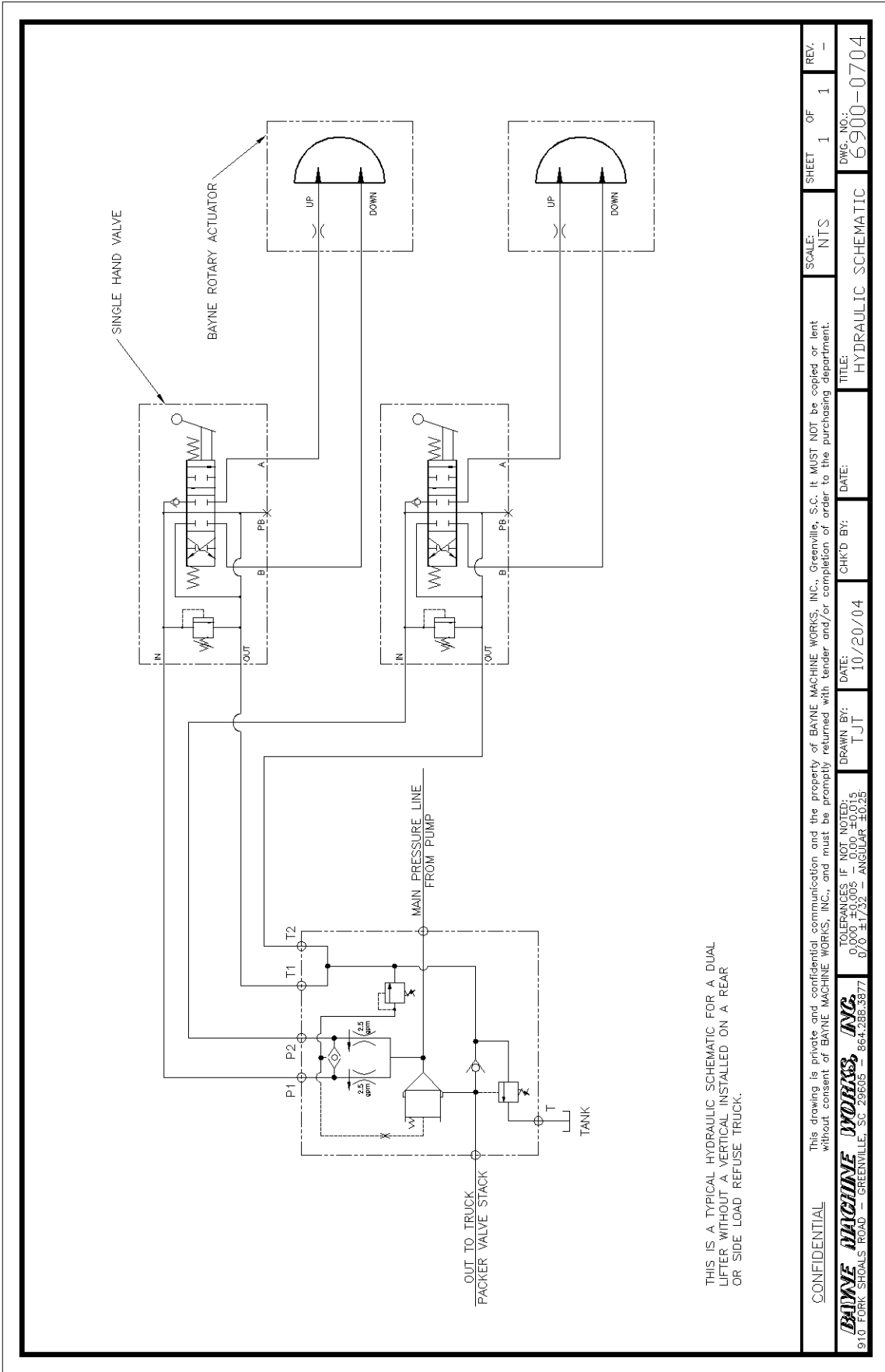

CONFIDENTIAL	This drawing is private and confidential communication and the property of BAYNE MACHINE WORKS, INC., Greenville, S.C. It MUST NOT be copied or lent without consent of BAYNE MACHINE WORKS, INC., and must be promptly returned with tender and/or completion of order to the purchasing department.	SCALE: NTS	SHEET 1 OF 1	REV: -
<b>BAYNE MACHINE WORKS, INC.</b> 910 FORK SHOALS ROAD - GREENVILLE, SC 29605 - 864.288.3877	DRAWN BY: T.J.T.	DATE: 10/20/04	CHK'D BY:	DATE:
	TOLERANCES: IF NOT NOTED: 0.000 ±0.005 - 0.000 ±0.015 0.0° ±1.732 - ANGULAR ±0.25	TITLE: HYDRAULIC SCHEMATIC	DWG. No.: 6900-0704	

# MBTL 180

## Appendix A - Assembly Drawings and Part Numbers

<i>SERVICE PARTS</i>			
ITEM	PORT	PART NO.	DESCRIPTION
1	DPS	6091-0716	DIFF. PRESSURE SENSING VALVE
2	RV	6091-0712	RELIEF VALVE
3	PSV	6091-0713	PRESSURE SEQUENCE VALVE
4	FR-1	6091-0710	FLOW REGULATOR
5	FR-2	6091-0710	FLOW REGULATOR
6		6091-0715	CAVITY PLUG
7	DSV	6091-0720	SHUTTLE VALVE
8		6246-0008	IND. 8 SAE SOCKET HEAD PLUG
9	CV	6091-0714	CHECK VALVE
10	DR	6066-0028	Ø.028" DRIFICE
			SEAL KIT
			APPLICATIONS

**NOTE:**

1. MAXIMUM WORKING PRESSURE 3000 PSI
2. MAXIMUM WORKING FLOW 50 GPM
3. TEMPERATURE RANGE = 160° MAXIMUM
4. PORT SIZES  
IN & OUT = #16 SAE  
T = #10 SAE
5. T1, T2, P1 & P2 = #6 SAE  
T1, T2, P1 & P2 ARE PLUGGED USING #6 SAE PLUGS IN SINGLE LIFTER APPLICATIONS

<b>CONFIDENTIAL</b>	This drawing is private and confidential communication and the property of BAYNE MACHINE WORKS, INC., Greenville, S.C. It MUST NOT be copied or lent without consent of BAYNE MACHINE WORKS, INC., and must be promptly returned with tender and/or completion of order to the purchasing department.	SCALE: 1=2	SHEET 1 OF 1	REV. A
<b>BAYNE MACHINE WORKS, INC.</b>	TOLERANCES: IF NOT NOTED: 0.000 ±0.005 - 0.000 ±0.015 0.076 ±1.732 - ANGULAR ±0.25	DRAWN BY: T.J.T.	DATE: 09/24/04	CHK'D BY: C.T.T.
810 FORK SHOALS ROAD - GREENVILLE, SC 29605 - 864.286.3877	DATE: 10/11/04	TITLE: DIVERTER VALVE PARTS	DWG. NO.: M3500005	

# MBTL 180

## Appendix A - Assembly Drawings and Part Numbers

ITEM NO	PART NO.	DESCRIPTION	QTY
1	8000-0781	PRES. SEQUENCE VALVE SEAL KIT	1
2	8000-0782	PRESSURE SENSING VALVE SEAL KIT	1
3	8000-0783	SHUTTLE VALVE SEAL KIT	1
4		RELIEF VALVE SEAL KIT	1
5	8000-0784	FLOW REGULATOR SEAL KIT	1
6		FLOW REG. CAVITY PLUG SEAL KIT	1
7		CHECK VALVE SEAL KIT	1

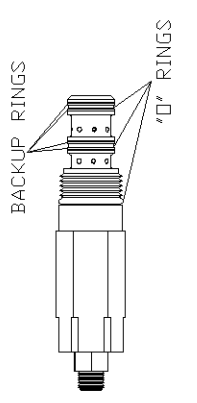

BACKUP RINGS  
"O" RINGS

PRESSURE SEQUENCE VALVE SEAL KIT

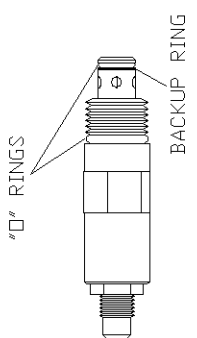

"O" RINGS  
BACKUP RING

RELIEF VALVE SEAL KIT

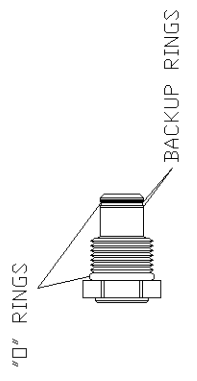

"O" RINGS  
BACKUP RINGS

FLOW REGULATOR CAVITY PLUG SEAL KIT

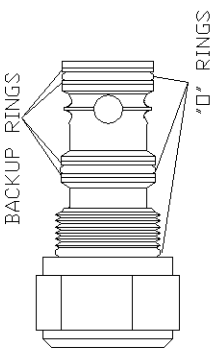

BACKUP RINGS  
"O" RINGS

DIFFERENTIAL PRESSURE SENSING VALVE SEAL KIT

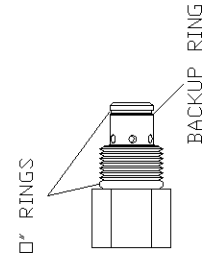

"O" RINGS  
BACKUP RING

FLOW REGULATOR SEAL KIT

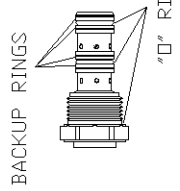

BACKUP RINGS  
"O" RINGS

SHUTTLE VALVE SEAL KIT

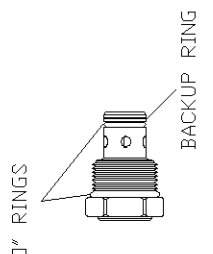

"O" RINGS  
BACKUP RING

CHECK VALVE SEAL KIT

CONFIDENTIAL This drawing is private and confidential communication and the property of BAYNE MACHINE WORKS, INC., Greenville, S.C. It MUST NOT be copied or lent without consent of BAYNE MACHINE WORKS, INC., and must be promptly returned with tender and/or completion of order to the purchasing department.	SCALE: 2=3	SHEET 1 OF 1	REV. -
BAYNE MACHINE WORKS, INC. 810 FORK SHOALS ROAD - GREENVILLE, SC 29605 - 864.286.3877	TOLERANCES: IF NOT NOTED: 0.000 ±0.005 - 0.00 ±0.015 0.70 ±1.732 - ANGULAR ±0.25	DRAWN BY: TJT DATE: 09/29/04 CHK'D BY:	TITLE: VALVE SEAL KIT DWG. NO.: 8000-0780

# MBTL 180

## Appendix A - Assembly Drawings and Part Numbers

ITEM	PART NO.	DESCRIPTION	QTY
1	6083-1025	HAND VALVE - 1750 PSI RELIEF	1
2	6083-1510	UNIVERSAL C-HOOK	1
3	6083-1511	CLEVIS PIN (ø3/16" x 7/8")	1
4	6083-1520	METRO/EATON H.V. HANDLE	1
5	8810-0303	COTTER PIN (1/16" x 1/2")	2
6	6220-0806	ST ADAPTER (#6 JIC x #6 SAE)	2
7	6248-0006	#6 JIC CAP NUT	2
8	7601-0003	HAND VALVE MOUNTING BRACKET	1
9	9001-0416	1/4-20 x 2" H.H.C.S.	2
10	9401-0400	1/4-20 HEX NUT	2
11	9700-0400	1/4" LOCK WASHER	2

**NOTE:**

1. SEAL REPAIR KIT P/N : 8000-0085
2. HANDLE REPLACEMENT KIT P/N : 6083-1501

E	6083-1025 WAS 6083-1020 ADDED 6083-1510 & 6083-1511 ADDED 6083-1520 & 8810-0303	05/24/07	CTT	1	1	C1515
D	REVISED 6083-1020 PICTORIALY	07/13/05	T JT	CTT	1	C1145
C	REVISED 6083-1020 PICTORIALY	03/30/99	TBR	RTM	1	C1167
B	6083-1020 WAS 6083-0420 ADDED 6220-0806 & 6248-0006 UPDATED DRAWING & TITLE BLOCK	05/15/98	CTT	RTM	1	C1049
A	REVISED 7601-0003 PICTORIALY	08/27/97	EFJ	RTM	1	C0929

REV.	REV.	DATE	BY	CHK.	APP.	DATE	BY	CHK.	APP.

**CONFIDENTIAL**

This drawing is private and confidential communication and the property of BAYNE MACHINE WORKS, INC., Greenville, S.C. It MUST NOT be copied or lent without consent of BAYNE MACHINE WORKS, INC., and must be promptly returned with tender and/or completion of order to the purchasing department.

SCALE: 2=3

SHEET 1 OF 1

REV. E

DATE: 06/11/96

CHKD BY: BKB

DRAWN BY: TBR

DATE: 06/07/96

DATE: 06/11/96

DATE: 06/11/96

DATE: 06/11/96

**BAYNE MACHINE WORKS, INC.**

910 FORK SHOALS ROAD - GREENVILLE, SC 29605 - 864.286.3877

TOLERANCES: IF NOT NOTED:  
 0.000 ±0.005 - 0.00 ±0.015  
 0.70 ±1.732 - ANGULAR ±0.25

TITLE: VALVE W/BRACKET

DWG. NO.: 6083-1010

# MBTL 180

## Appendix A - Assembly Drawings and Part Numbers

ITEM NO.	DESCRIPTION	QTY
1	RETAINING RING	1
2	3/32" x 1/2" I.D. O-RING	2
3	WIPER SEAL	1
4	3/32" x 41/64" I.D. O-RING	1
5	3/32" x 3/8" I.D. O-RING	1
6	1/16" x 1/2" I.D. O-RING	1
7	1/16" x 1/2" BACK-UP WASHER	1
8	3/32" x 5/8" I.D. O-RING	1
9	5/64" x 15/32" I.D. O-RING	1

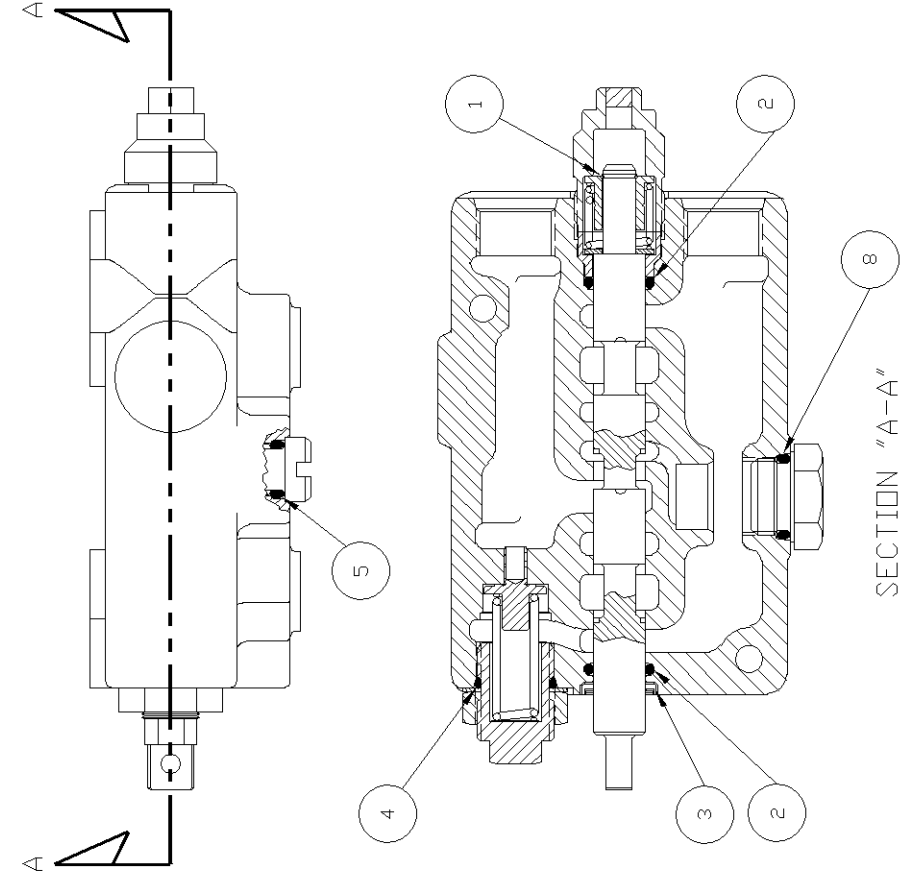

NOTES:

1. ASSEMBLY INSTRUCTIONS ARE INCLUDED WITH EACH KIT.
2. ITEMS 6,7 AND 9 ARE NOT USED WITH THIS HAND VALVE.

SECTION "A-A"

<b>CONFIDENTIAL</b>	This drawing is private and confidential communication and the property of BAYNE MACHINE WORKS, INC., Greenville, S.C. It MUST NOT be copied or lent without consent of BAYNE MACHINE WORKS, INC., and must be promptly returned with tender and/or completion of order to the purchasing department.	SCALE: 1=1	SHEET 1 OF 1	REV. -
<b>BAYNE MACHINE WORKS, INC.</b> 910 FORK SHOALS ROAD - GREENVILLE, SC 29605 - 864.288.3877	TOLERANCES: IF NOT NOTED: 0.000 ±0.005 - 0.000 ±0.015 0.70 ±1.732 - ANGULAR ±0.25	DATE: 07/20/05	CHK'D BY: TJT	DWG. No.: 8000-0085
TITLE: HAND VALVE SEAL REPAIR KIT				



# MBTL 180

## Appendix A - Assembly Drawings and Part Numbers

<p>CONFIDENTIAL</p> <p>This drawing is private and confidential communication and the property of BAYNE MACHINE WORKS, INC., Greenville, S.C. It MUST NOT be copied or lent without consent of BAYNE MACHINE WORKS, INC., and must be promptly returned with tender and/or completion of order to the purchasing department.</p> <p><b>BAYNE MACHINE WORKS, INC.</b>          919 FORK SHOALS ROAD - GREENVILLE, SC 29605 - 864.286.3877</p>	<p>SCALE: 1=3</p>	<p>SHEET 1 OF 1</p>	<p>REV. A</p>
<p>TOLERANCES: IF NOT NOTED:          0.000 ±0.005 - 0.000 ±0.015          0.70 ±1.732 - ANGULAR ±0.25</p>	<p>DATE: 04/18/00</p>	<p>CHK'D BY: CTT</p>	<p>DWG. No.: LUB4200</p>
<p>TITLE: MBTL LUBRICATION POINTS</p>			

# MBTL 180 INDEX

## A

adjusting relief valve settings 4

## D

diverter valve information  
operation and installation information 12  
possible problems 12

## F

final operation and mounting 4

## I

installation instructions 4  
instructions  
actuator assembly 15  
slowdown assembly 15

## L

lower hook adjustment 10

## M

maintenance instructions 14  
making hydraulic connections 4  
mounting 4

## O

operation instructions 10

## S

safety 2  
safety zones 10  
specifications 3

## T

troubleshooting chart 23





[www.baynethinline.com](http://www.baynethinline.com)

Customer Care:  
800.535.2671

Bayne Premium Lift Systems  
4301 Gault Avenue North  
Fort Payne, AL 35967