

CUSTOMER APPROVAL DRAWING

This drawing is private and confidential communication and the property of BAYNE MACHINE WORKS, INC., Greenville, S.C. It MUST NOT be copied or lent without consent of BAYNE MACHINE WORKS, INC.

SUBMITTED FOR YOUR APPROVAL

This proposal drawing will not be released for production without a signed approval. Please review this drawing and the product shown carefully and mark all changes required.

This drawing supersedes all drawings of previous issue. Destroy all drawings of this part number issued prior to this date:

05/24/2006

Name _____ Date _____

Title _____ Company _____

NOTE:

1. COMPATIBLE CONTAINERS:
ANSI Z245.60-1996 TYPE B (DOMESTIC TWO-BAR) CONTAINERS
AMERI-KART 1 CU. YD. MATERIAL HANDLING CART
2. LIFT CAPACITY : 1000 lbs @ 2500 PSI
3. CYCLE TIME: 10 SECONDS @ 2.5 GPM
4. POWER UNIT: 5 HP MOTOR (460V three-phase)
2.5 GPM GEAR PUMP
4 GAL. OIL RESERVOIR
2500 PSI MAXIMUM PRESSURE
KEYED ON/OFF SWITCH
HAND HELD PENDENT CONTROLS W/ 6' CORD
5. ALL DIMENSIONS ARE APPROXIMATE.

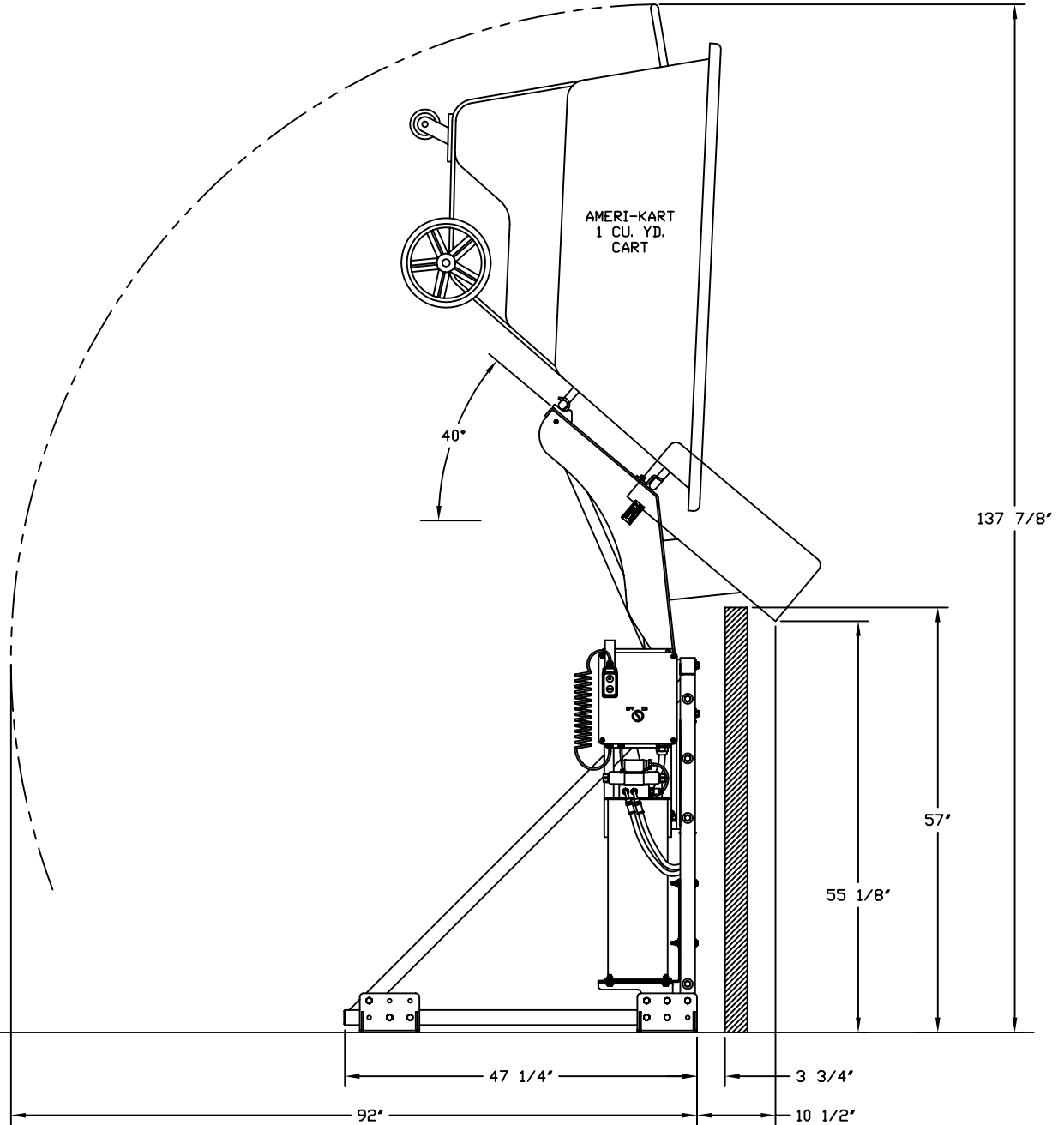
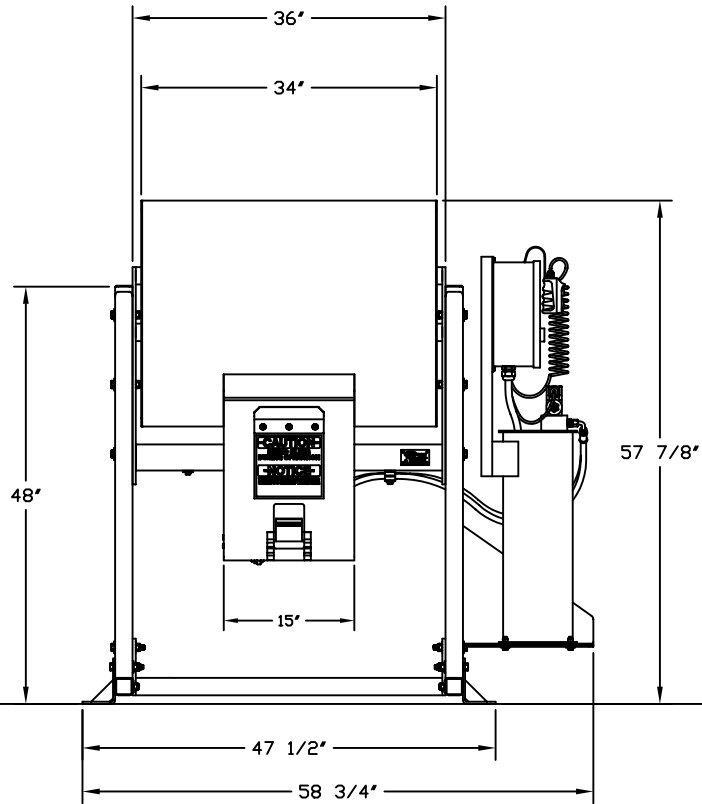

AMERI-KART
1 CU. YD.
CART

CONFIDENTIAL

This drawing is private and confidential communication and the property of BAYNE MACHINE WORKS, INC., Greenville, S.C. It MUST NOT be copied or lent without consent of BAYNE MACHINE WORKS, INC., and must be promptly returned with tender and/or completion of order to the purchasing department.

SCALE: 1=11 SHEET 1 OF 1 REV.

BAYNE MACHINE WORKS, INC.
910 FORK SHOALS ROAD - GREENVILLE, SC 29605 - 864.288.3877

TOLERANCES IF NOT NOTED:
0.000 ±0.005 - 0.00 ±0.015
0/0 ±1/32 - ANGULAR ±0.25

DRAWN BY: CTT

DATE: 03/09/05

CHK'D BY:

DATE:

TITLE: SHLF-RGD-460-RHC

DWG. NO.: H5800008